



Q3 ENERGIE

GmbH & Co. KG ■ ■ ■

QFire Installation & Operation Manual

PV Generator Disconnection Device according to IEC 60947-3

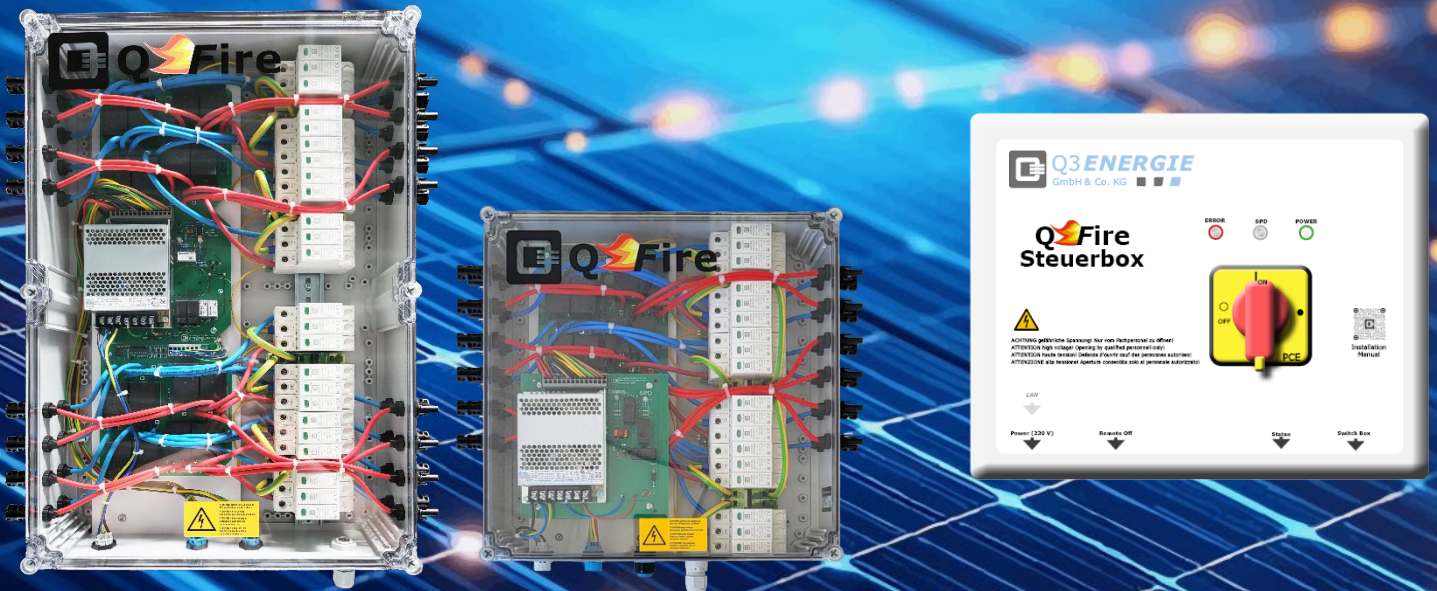

Q Fire

Version 1.6
Release Date: 07 April 2018
Document No.: QF-IO-EN-001
Language: English

Q3 ENERGIE GmbH & Co. KG
www.q3-energie.de



This document describes the installation, operation, and maintenance of the QFire Fireman's Switch for photovoltaic systems.

Document Title Installation & Operation Manual – QFire Fireman's Switch
Document Type Technical Manual

Version 1.6
Release Date 07 April 2017
Document Number QFire-IO-EN-001
Language English
Status Released

Company Q3 ENERGIE GmbH & Co. KG
Website www.q3-energie.de
Email service@q3-energie.de

Author Thomas Neumann
Approval Gregor Lammel

Version	Date	Description
1.0	07.04.2027	Initial release
1.6	07.04.2026	Updated layout & technical structure



Inhaltsverzeichnis

Inhalt

1 Safety Instructions.....	5
1.1 Icons and their meaning	5
1.2 Device Information	6
1.3 Guarantee	6
1.4 Disclaimer of Liability	7
1.5 Intendend Use	8
1.6 Non Intenden Use.....	8
2 System Description	9
2.1 QFire – Layout	10
2.1.1 Cable Specifiation	11
2.1.2 Optional Emergency Stop	12
2.2 QFire Extensions	13
2.2.1 QFire Cluster Control Box	13
2.2.2 QFire.LIVE Maintenance Tool	13
2.3 QFire – Components	14
2.3.1 Control Box	14
2.3.2 Switch Box	15
2.3.3 Type Plates	16
2.4 QFire Functions.....	16
2.4.1 LED Status Indication.....	17
2.4.3 Turning-Off Manually	18
2.4.4 Turning-Off Automatically.....	20
3 Delivery Content	21
3.1 Unpacking.....	21
3.2 Parts List	21
4 Installation	25
4.1 Installation Point.....	25
4.2 Mounting	26
4.3 Connections	26
4.3.1 Control Lines of the QFire System	27
4.3.2 Power Supply	29
4.3.3 PV String Lines to Switch Box	30
4.3.4 Status Contact on the Control Box	32
4.3.5 Optional Connections	34



5	START-UP	39
6	Maintenance Service	41
6.1	Maintenance Interval	41
6.1.1	Functional Test	41
6.2	Documents	42
6.3	Technical Support	42
7	Troubleshooting and Remedy	43
8	Certifications	44
8.1	CE Declaration of Conformity	44
8.2	Certificate of Compliance	46
9	Technical Data	48
9.2	Control Box	48
9.3	Cluster Control Box	48
9.4	Switch Box 2 Strings	49
9.5	Switch Box 4 Strings	49
9.6	Switch Box 6 Strings	50
9.7	Switch Box 8 Strings	50
9.8	Switch Box 10 Strings	51
9.9	Switch Box 12 Strings	51
9.10	Switch Box 14 Strings	52
9.11	Switch Box 16 Strings	52
9.12	Switch Box 18 Strings	53
9.13	Switch Box 20 Strings	53
9.14	Switch Box 22 Strings	54
9.15	Switch Box 24 Strings	54
9.16	Q3 SPD	55
10	Disposal	56



1 Safety Instructions

1.1 Icons and their meaning

Read all safety instructions very carefully! The observance of all instructions, the proper use and the application according to the instructions is binding for product liability and product guarantee. Be sure to pass this information on to other people who use this device!



DANGER
identifies dangerous situations that will result in serious injury or death, if ignored.



ATTENTION
identifies important information that will result in material damages or injury, if ignored.



VOLTAGE
identifies dangerous voltage situations that will result in serious injury or death, if ignored.



HINT
indicates important information and useful hints.



SQUEEZING
identifies dangerous situations for hands/fingers that will result in squeezing injury, if ignored.



SUPPORT
In case of any questions, please contact our Q3 Support.



CUT
identifies dangerous situations for hands/fingers that will result in injury, if ignored. Wear protection gloves!



INFO
The marked passages refer to further or supplementary information, such as documents or internet links.



FIRE
identifies dangerous situations that will result in fire, if ignored.



1.2 Device Information

The technology and equipment of the product described here are state-of-the-art in terms of functionality and safety. Further developments and improvements are taken into account on an ongoing basis.

As a result, the illustrations, dimensions, technical data, and general content listed below may change as a result of adaptation to new knowledge. This manual is intended to help you to optimally and safely operate our product, which has been developed and manufactured according to the latest technology, with its versatile possibilities. Please read these instructions carefully before start-up and always keep the manual close to the device for quick access, if needed.

- In principle, the device may only be opened or repaired by authorized personnel. Never open the device or make any repairs to the device yourself.
- Avoid constant high humidity and condensation. Protect the QFire enclosure from splashes, floods and chemicals.



The safe operation of the device is generally guaranteed if the instructions in this manual and on the device are observed.



In case of any questions, please contact our service team:
service@q3-energie.de



Safe operation of the device is no more possible, in the case of:

- smoke coming out of the device
- defective connecting cables
- it is no more working properly
- the housing is damaged

1.3 Guarantee

We guarantee that the goods delivered by us have the specified properties. The duration of guarantee is 24 months, unless otherwise agreed in writing, and is calculated from the registration of the QFire system at Q3 Energie GmbH & Co. KG from the authorized specialist company that carried out the installation and connection of the QFire system.

As the manufacturer of the QFire - Fire Brigade Switch, we confirm that:

- by turning the mains switch S1 to position „0“ (=off), the PV system (string lines) from the QFire control box to the inverter is set power-free.

As the manufacturer of the QFire - Fire Brigade Switch, we certify that:

- the QFire - Fire Brigade Switch complies to the valid norm IEC60947-3.



1.4 Disclaimer of Liability

We explicitly state that all product liability and guarantee claims are null and void:

- 1.** if the QFire system has not been installed, connected and approved by a specialist company (start-up protocol).
- 2.** if the QFire system is operated on a photovoltaic plant, which was not erected according to norm VDE-AR-N 4105.
- 3.** if the QFire system is operated on a photovoltaic plant, which has no lightning overvoltage protection (earthing).
- 4.** if the QFire system is not installed/operated in accordance with the instructions described in this manual.
- 5.** if the QFire system is operated outside of its intended use, see chapter 1.5 INTENDED USE and chapter 1.6 NON INTENDED USE.
- 6.** if the QFire system is operated outside of its specification.
- 7.** if a defect that has occurred is not immediately asserted in writing.
- 8.** when opening and operating the QFire system in a faulty condition.
- 9.** if own repair attempts have been made which have not been approved in writing by the manufacturer Q3 Energie GmbH & Co. KG.
- 10.** when using/installing non-original spare parts and accessories.
- 11.** for overvoltage damage due to lightning.
- 12.** for damage caused by liquids (e.g. flooding, burst pipes, fire extinguishing).
- 13.** for mechanical damage and its consequential damage after successful installation (start-up protocol).
- 14.** for damage caused by overuse (frequent switching of switch S1 not in accordance with the application) or exposure to foreign bodies.
- 15.** for normal wear and tear.
- 16.** in case of optical defects.
- 17.** for damages due to force majeure, natural disaster or war.



1.5 Intendend Use

- The product is to be used only for the purpose described in chapter 2 SYSTEM DESCRIPTION. Under no circumstances may it be used for any other purpose and may not be operated outside the technical limits!
- Also, make sure that the connected components are in a safe condition and suitable for operation with the product.
- Make sure that the product is installed on a suitable installation point according to chapter 4.1 INSTALLATION POINT.

1.6 Non Intenden Use

- Usage of the device outside the intended use according to chapter 1.5 INTENDED USE.
- Non intended use is any type of use not described in this document.
- Usage/installation of parts and accessories others than the manufacturer's original's.
- Usage of the device in non-compliance to this manual.
- Changes/modifications not approved by Q3 Energie GmbH & Co. KG will void the user's authority to operate the equipment.
- Not complying to the safety instructions.



In the event of an application that does not meet the specification, there is a risk of personal injury, electric shock, fire and damage to the product and the connected components!



2 System Description

The QFire Brigade Switch is intended exclusively for operation on a photovoltaic system. High voltages (up to 1,500 VDC) as well as strong electrical currents can occur!



Improper operation and incorrect handling can result in danger to life and body!

QFire is a PV generator shutdown device for automated galvanic isolation of PV strings according to DIN EN 60947-3:2020.

It serves the purpose of:

- galvanically disconnecting the PV generator up from the installation point of the QFire product, if necessary (e.g. in case of fire).
- visually displaying the status of the PV system in operation, cable breakage of the control line, PV system "switched off".
- fending-off dangers from people, animals, buildings and objects!



When used as intended and installed properly and professionally, the QFire system will perform the function reliably according to the system description! Please take the time to read this document carefully.

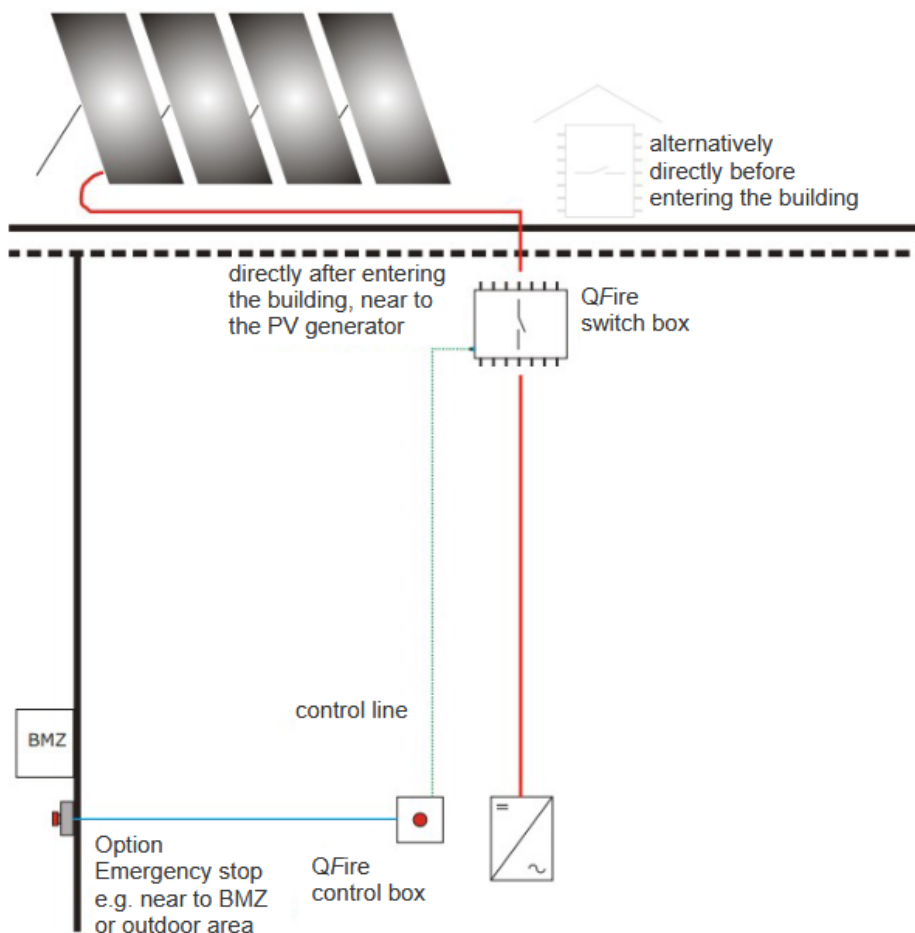

Figure 1: Overview mounting position



2.1 QFire – Layout

The QFire system consists of a control box and one or more switch box(es). The housings are UV-resistant and UV-repellent and are available in grey or transparent. The last switch box has to be finished with the dongle. (The dongle is included in the delivery content of the control box.)

The control box is used to switch-off and -on the switch boxes centrally, as well as to display the status of the system. Optionally SPDs surge protective devices are installed in the switch boxes. The status of the SPDs is displayed on each switch box as well as in its entirety on the control box LED (SPD), see chapter 2.4.1 LED STATUS INDICATION.

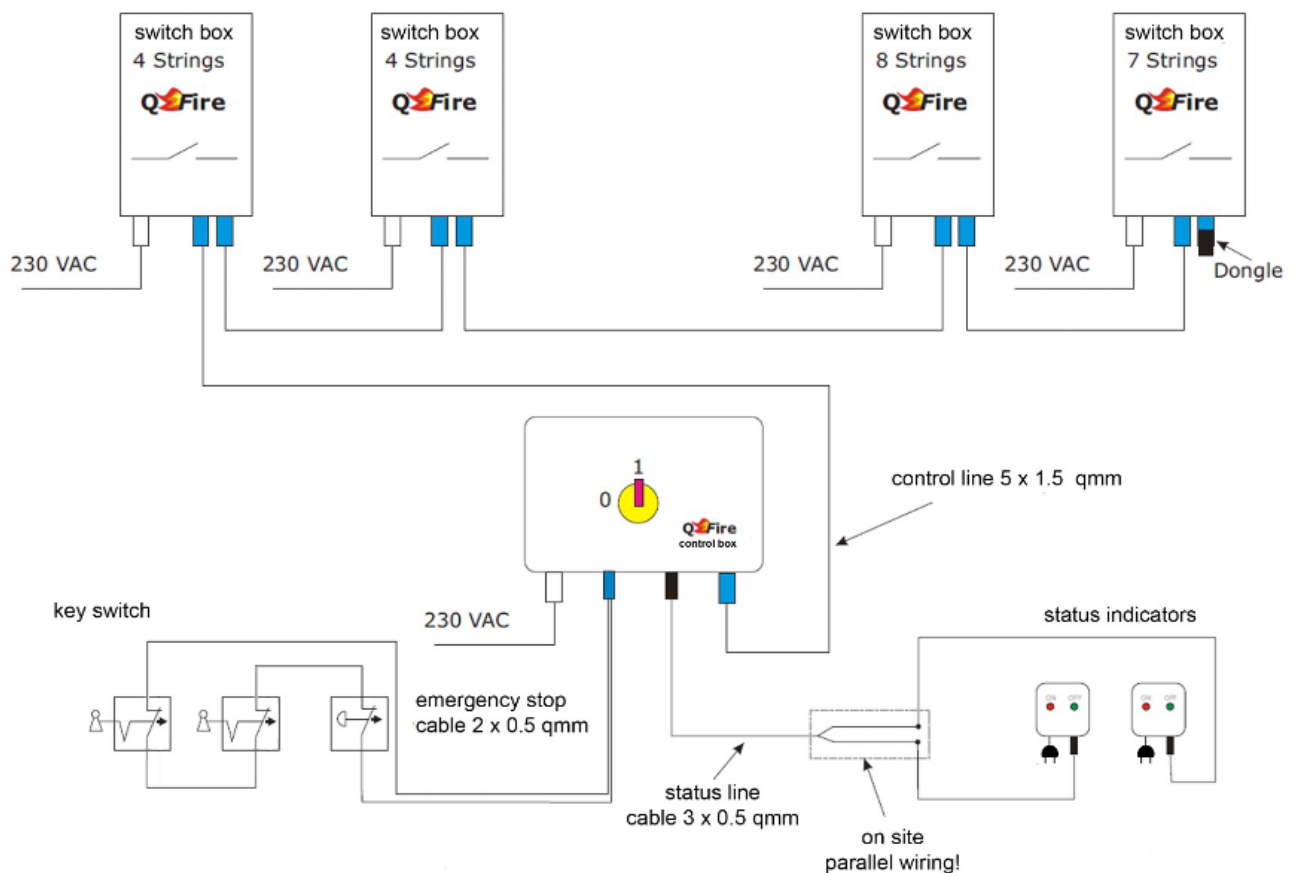

Figure 2: Layout example

Components according to figure 2:

- Shown connection plugs are included. (The dongle is included in the delivery content of the control box.)
- All cables have to be provided on-site, see chapter 2.1.1 CABLE SPECIFICATION.
- Potential-free switches are optionally available from Q3 Energie GmbH & Co KG for:
 - Emergency stop
 - Status display (preconfigured plug for power socket connection)

Delivery content overview, see chapter 3 DELIVERY CONTENT.



2.1.1 Cable Specification

from – to	Description	Cable diameter	Plug
Control box – Switch box 1	Control line, 5-wire, color or number coded	2.5 mm ² without core end sleeve 1.5 mm ² with core end sleeve	Wieland 46.052.4553.9
Switch box – Switch box	Control line, 5-wire, color or number coded	2.5 mm ² without core end sleeve 1.5 mm ² with core end sleeve	Wieland 46.052.4553.9 and Wieland 46.051.4553.9
Control box – emergency stop switch	2-wire	0.5 mm ²	Wieland 4L.022.3043.9
Control box – key switch	2-wire	0.5 mm ²	Wieland 4L.022.3043.9
Control box – BMZ	3-wire	0.5 mm ²	Wieland 4L.032.3053.1
Control box – 230 VAC	3-wire with protective conductor	2.5 mm ²	Wieland 46.031.4453.1
Switch box – 230 VAC	3-wire with protective conductor	2.5 mm ²	Wieland 46.051.4553.0
Switch box – PV strings	on-site from PV generator	on-site from PV generator	MC4 (Stäubli EVO2)



2.1.2 Optional Emergency Stop

The QFire system is centrally turned off by the mains switch (0 off) at the control box. Depending on the installation position of the control box optional/additional external emergency switches are necessary.



The emergency stop / key switch must NOT be operated deliberately or accidentally by unauthorized persons! If this cannot be ruled out (e.g. school), the "behind-glass" variant must be installed. Article number see 3.2 PARTS LIST.



Emergency stop push button



Emergency stop button «behind-glass»



Key switch



Key Switch: The key can only be removed in position 0 (= PV system switched off) as a protection from restarting during fire extinguishing work.

For assembling and connection refer to chapter 4.3.5.3 EXTERNAL EMERGENCY SWITCH.



2.2 QFire Extensions

2.2.1 QFire Cluster Control Box

The QFire system can not only switch off several switch boxes by means of 1 control box, but can also communicate intelligently in conjunction with other control boxes, which in turn manage several switch boxes. A cluster can be switched off centrally via 1 emergency stop. Ideal for factory sites with several buildings.

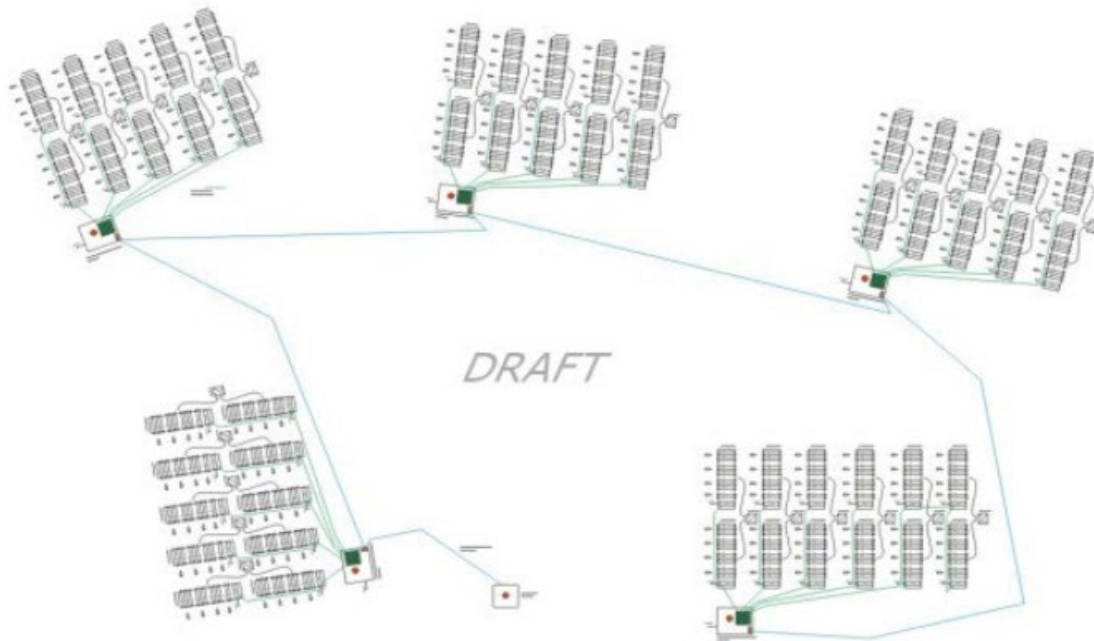

Figure 3: Overview interconnection of cluster control boxes



Detailed information about QFire Cluster can be downloaded from our website: www.q3-energie.de.

2.2.2 QFire.LIVE Maintenance Tool

The QFire system status can also be called up mobil in the internet via QFire.LIVE maintenance tool:



Figure 4: QFire.LIVE status overview



Detailed information about QFire.LIVE can be downloaded from our website: www.q3-energie.de.



2.3 QFire – Components

2.3.1 Control Box

The control box must be installed in an accessible place.

Mains switch (4) is used to switch-on and switch-off the QFire system / PV generator according to chapter 2.4 QFire FUNCTIONS.

To prevent accidental restarting, the mains switch can be locked in the „0“ position (5) using the small yellow lever (6), which additionally can be blocked by a padlock. Its LEDs are indicating the QFire system status, see chapter 2.4.1 LED STATUS INDICATION.

Optionally, an external status indicator (10) or an emergency stop remote OFF (8) can be connected.



No.	Description
1	LED Error (red)
2	LED SPD surge protective device (red/green)
3	LED Power (green)
4	Mains switch S1 position „on“ „I“
5	Mains switch S1 position „off“ „0“
6	Locking lever position „off“ „0“
7	Power supply 230 VAC
8	Connection Emergency stop / key switch optional
9	Ventilation opening (condensate)
10	Connection Status (potential-free switch) optional
11	Connection control line (Wielandstecker)
12	Dongle for last switch box (within the delivery content of control box)

Figure 5: Control box

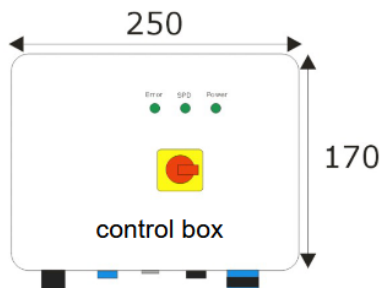

Figure 6: Dimensions control box in mm



Figure 7: Bridge set in connector (8) emergency stop / key switch



Figure 8: Wieland plug for connecting to switch box(es) (11)



2.3.2 Switch Box

The switch box is installed immediately after the PV string cables have entered the roof. It contains the switching device for galvanic isolation of the PV strings. It is controlled by the control box connected via control line (5).

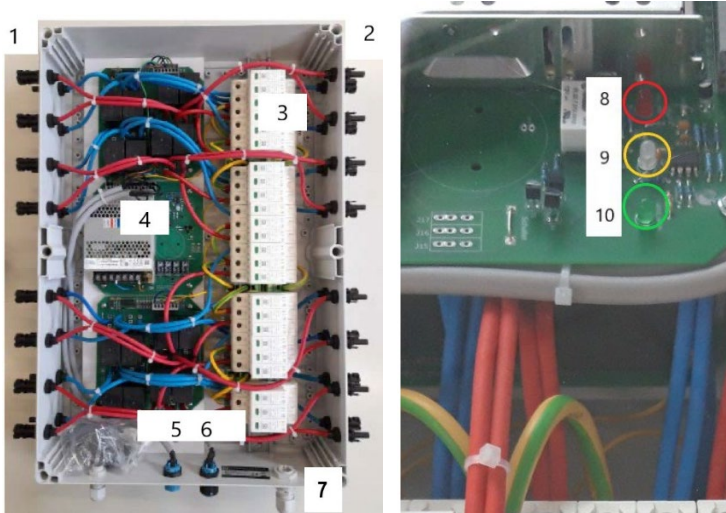

Figure 9: Example switch box for 8 strings with integrated SPD (option)

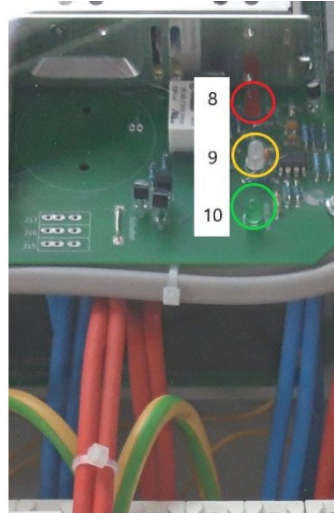

Figure 10: LEDs

No.	Description
1	8 strings +/- from PV generator
2	8 strings +/- to PV inverter
3	Overvoltage contactors SPD (Surge Protection Device)
4	Slave power supply
5	Connector for control lines to the control box or previous switch box(es)
6	Connector for control lines to additional switch box(es) or for termination dongle *
7	Insert for PE
8	LED Error (red)
9	LED SPD surge protective device (red/green)
10	LED Power (green)

* Dongle (included in control box delivery content)

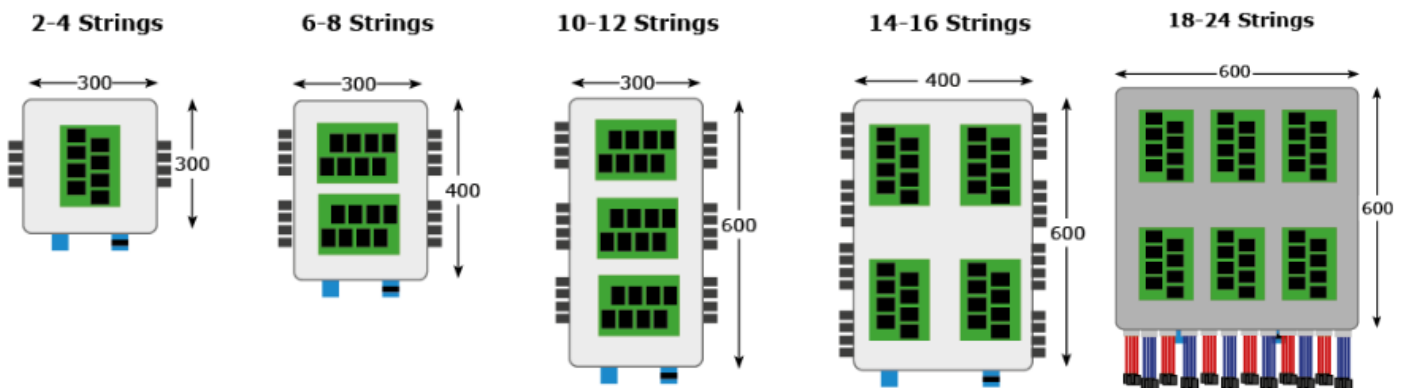

Figure 11: Dimensions of switch box housing sizes in mm



Depending on the configuration of the options, suitable housing sizes are used specifically for the customer. Please inquire the dimensions for your application.



2.3.3 Type Plates



Figure 12: Type plate control box



Figure 13: Type plate switch box

2.4 QFire Functions

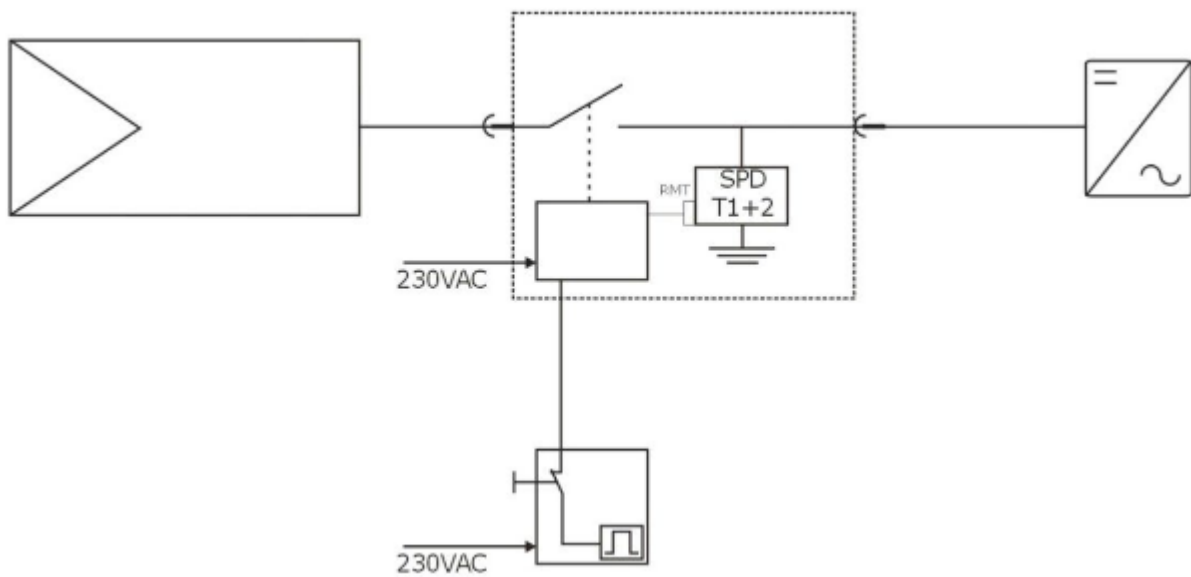

Figure 14: Functional Diagram QFire



2.4.1 LED Status Indication



Error	SPD optional	Power	System
off	green	green	<p>QFire-Control Box turned on QFire-Switch Box turned on SPD-Surge Protective Device ok</p> <p>QFire-System in operation PV-System in operation DC-Strings conducting up to the inverter</p>
off	red	green	<p>QFire-Control Box turned on QFire-Switch Box turned on SPD-Surge Protective Device defective</p> <p>QFire-System in operation PV-System in operation DC-Strings conducting up to the inverter input</p>
red	red	green	<p>Failure in QFire system</p> <p>QFire-System switch off control box (mains switch OFF, '0'-position) PV-System status must be controlled DC-Strings eventually only partly turned off</p> <p>Check control line</p>
off	off	off	<p>QFire-Control Box turned off QFire-Switch Box switches the PV-system power-free up to the inverter input</p> <p>QFire-System QFire-Switch Box turned off DC-Strings power-free up to QFire-Switch Box</p>



ATTENTION: PV generator is only cut-off, if the control box

- mains switch is in OFF "0"-position
- shows that all LED's are off



2.4.2 Turning-On Manually

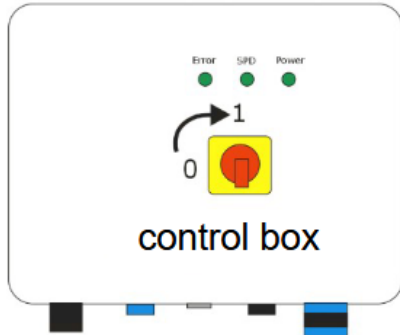

Turn-on the connection PV generator – PV inverter:

If the mains switch S1 is turned on (position „1“) at the control box, a signal is transmitted to the switch box via the control line.

As a result, the relays in the switch box are tightened which connects the PV string lines with the inverter on plus and minus sides.

The status LED "Power" at the QFire control box lights up green.



Dangerous electrical voltage is applied after turning-on the control box!

2.4.2.1 Optional Monitoring of Overvoltage SPD

A surge protection device (3/ Fig. 9) can optionally be installed in each MPP tracker in the switch box. These can optionally be monitored.

If none of the SPD modules has a defect due to an overvoltage, the status LED SPD lights up green on the control box. A defect due to overvoltage is signalled in red.



Defective SPD modules must be exchanged immediately in order to ensure device protection in the event of an overvoltage!

2.4.3 Turning-Off Manually

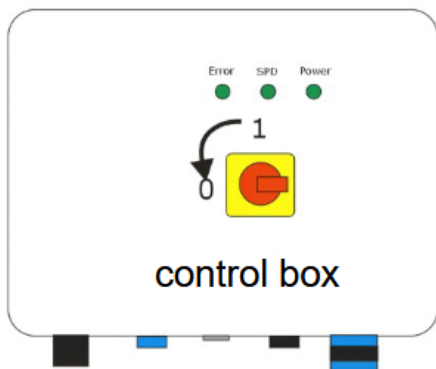

Turn-off the connection PV generator – PV inverter:

If the mains switch S1 is turned off (position „0“), the control box transmits via the control line a signal to the switch boxes for simultaneous shutdown.

Optionally a delay circuit for time-shifted shutdown is available. Please inquire.

The relays of the switch box(es) disconnect the PV strings lines to the inverter on plus and minus sides.

Up from the switch box, the cables in the direction to the inverter no longer carrying voltage. All status LEDs are off!



2.4.3.1 Turning-Off by External Switch (Remote OFF)

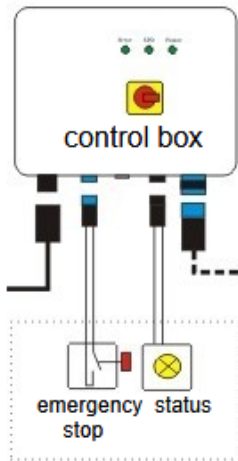

Optionally, a status indicator/potential-free contact (10/ Fig. 5) or an emergency stop remote OFF (8/ Fig. 5) can be connected externally.

In this way, the switch-off process can also be triggered externally for all switch boxes connected to the control box.

QFire system in operation: status contact closed
QFire system OFF: status contact opened

Also see chapter 2.1.2 OPTIONAL EMERGENCY STOP.

2.4.3.2 Switch-Off Without Control Box (230 V)

Disconnect the power supply:

The L1 conductor is routed through the emergency stop switch.

The emergency stop switch must be designed for 230 V operation.

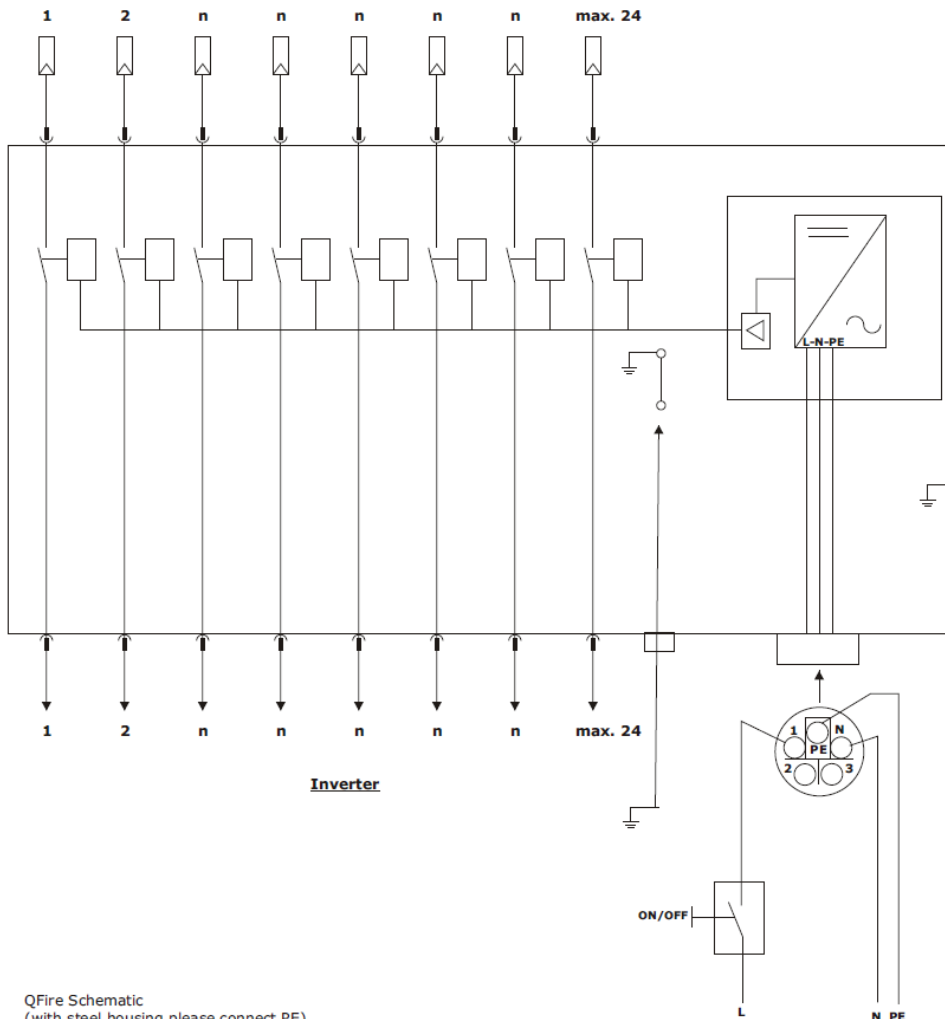

QFire Schematic
(with steel housing please connect PE)
(c) Q3 ENERGIE GmbH & Co. KG
2025 tns 1.0



2.4.3.3. Switch-Off Without Control Box (12/24 V control voltage)

Alternatively, the system can be switched off exclusively via an external switching device (e.g. emergency stop button).



For this purpose, a normally closed (NC) contact of the switching device is wired to pins 4 and 5 of the Wieland connector and connected to the plug of the first switch box.

For the control line between the switch boxes, only a 2 x 1.5 mm² control cable is required. In this case, only pins 4 and 5 of the Wieland connectors are used. A termination plug is not required.

2.4.3.3 Optional Shutdown Delay

For the shutdown process of larger systems, e.g. 2 MW, we recommend an optional delay circuit. Please specify when planning and ordering, see chapter 3.2 PARTS LIST.

2.4.4 Turning-Off Automatically

2.4.4.1 Caused by Power Grid Failure

If the AC power is switched off, all relay voltages automatically drop and the relays open/interrupt the circuit. The PV generator is switched off. If the AC grid is turned back on, the QFire system automatically switches the PV system back into operation.

2.4.4.2 Caused by Undervoltage

If there is a cable break within the control lines or if the control voltage drops below 9 VDC (e.g. in the case of strong fluctuations in the AC network), this is detected as an undervoltage and the PV-system is completely switched off. The LED ERROR on the QFire control box lights up red.

Once the error has been resolved, the correct status display and the functioning of the system can be restored by turning the S1 switch off and on again from 0 to 1.



3 Delivery Content

3.1 Unpacking



When unpacking, check that all supplied parts are complete and undamaged. Be sure to remove all parts from the packaging. Claims for damages caused during transport can only be asserted if the delivery service is notified immediately. Please prepare a damage report with appropriate photos and send it with the defective part immediately back to Q3 ENERGIE GmbH & Co. KG, see chapter 6.3 TECHNICAL SUPPORT.

The product is manufactured (customer specific), tested and packaged according to our strict quality standards. Each assembly has a serial number and is recorded in our QM system. Assemblies that are connected to high voltages have been specially checked and a test report is enclosed. If there is any reason for complaint, please have the serial number and test report available.



**Damaged products must not be installed and put into operation under any circumstances!
There is a risk of malfunction, electric shock and fire!**

3.2 Parts List

Control Boxes	
Article-No.	Product Description
500566	QFire Generator Disconnection Control Box with evaluation SPD and/or control of big boxes with integrated slave.
500567	QFire Generator Disconnection Cluster Control Box with evaluation of surge protective devices (SPD) and/or control of QFire BIG switch boxes with integrated slave. Supports control of up to 5 cluster contacts for operation of up to 5 QFire BIG systems. Enclosure rating: IP67 (The cluster card is available as a separate item)
500569	QFire Cluster Card for controlling one QFire BIG system.
Switch Boxes	
Article-No.	Product Description
Q-510602	QFire Big HV - 20 A* Switching Unit 2 PV Strings* . Remote-controlled switching unit "QFire" for disconnecting 2 PV strings. 2 inputs (2x + 2x -), 2 outputs (2x + 2x -). Housing made of polycarbonate, IP 66/67, for installation in weather-protected outdoor areas, 300 x 300 mm (may be larger with additional components). String input and output connections via Stäubli MC4 EVO2 connectors (others on request). Maximum string voltage 1,500 V DC, maximum Isc per string 20 A. Connection of a 5-pole control cable (5x 1.5 mm ²) to included connector (customer-provided cable). 4 mounting lugs included.



Q-510604	QFire Big HV - 20A* Switching Unit for 4 PV Strings* Remote-controlled switching unit "QFire" for disconnecting 4 PV strings. 4 inputs (4x + 4x -), 4 outputs (4x + 4x -). Housing made of polycarbonate, IP 66/67, for installation in weather-protected outdoor areas, 300 x 300 mm (may be larger with additional components). String input and output connections via Stäubli MC4 EVO2 connectors (others on request). Maximum string voltage 1,500 V DC, maximum Isc per string 20 A. Connection of a 5-pole control cable (5x 1.5 mm ²) to included connector (customer-provided cable). 4 mounting lugs included.
Q-510606	QFire Big HV - 20 A* Switching Unit for 6 PV Strings* Remote-controlled switching unit "QFire" for disconnecting 6 PV strings. 6 inputs (6x + 6x -), 6 outputs (6x + 6x -). Housing made of polycarbonate, IP 66/67, for installation in weather-protected outdoor areas, 300 x 300 mm (may be larger with additional components). String input and output connections via Stäubli MC4 EVO2 connectors (others on request). Maximum string voltage 1,500 V DC, maximum Isc per string 20 A. Connection of a 5-pole control cable (5x 1.5 mm ²) to included connector (customer-provided cable). 4 mounting lugs included.
Q-510608	QFire Big HV - 20 A* Switching Unit for 8 PV Strings* Remote-controlled switching unit "QFire" for disconnecting 8 PV strings. 8 inputs (8x + 8x -), 8 outputs (8x + 8x -). Housing made of polycarbonate, IP 66/67, for installation in weather-protected outdoor areas, 300 x 300 mm (may be larger with additional components). String input and output connections via Stäubli MC4 EVO2 connectors (others on request). Maximum string voltage 1,500 V DC, maximum Isc per string 20 A. Connection of a 5-pole control cable (5x 1.5 mm ²) to included connector (customer-provided cable). 4 mounting lugs included.
Q-510610	QFire Big HV - 20 A* Switching Unit for 10 PV Strings* Remote-controlled switching unit "QFire" for disconnecting 10 PV strings. 10 inputs (10x + 10x -), 10 outputs (10x + 10x -). Housing made of polycarbonate, IP 66/67, for installation in weather-protected outdoor areas, 300 x 300 mm (may be larger with additional components). String input and output connections via Stäubli MC4 EVO2 connectors (others on request). Maximum string voltage 1,500 V DC, maximum Isc per string 20 A. Connection of a 5-pole control cable (5x 1.5 mm ²) to included connector (customer-provided cable). 4 mounting lugs included.
Q-510612	QFire Big HV - 20 A* Switching Unit for 12 PV Strings* Remote-controlled switching unit "QFire" for disconnecting 12 PV strings. 12 inputs (12x + 12x -), 12 outputs (12x + 12x -). Housing made of polycarbonate, IP 66/67, for installation in weather-protected outdoor areas, 300 x 300 mm (may be larger with additional components). String input and output connections via Stäubli MC4 EVO2 connectors (others on request). Maximum string voltage 1,500 V DC, maximum Isc per string 20 A. Connection of a 5-pole control cable (5x 1.5 mm ²) to included connector (customer-provided cable). 4 mounting lugs included.
Q-510614	QFire Big HV - 20 A* Switching Unit for 14 PV Strings* Remote-controlled switching unit "QFire" for disconnecting 14 PV strings. 14 inputs (14x + 14x -), 14 outputs (14x + 14x -). Housing made of polycarbonate, IP 66/67, for installation in weather-protected outdoor areas, 300 x 300 mm (may be larger with additional components). String input and output connections via Stäubli MC4 EVO2 connectors (others on request). Maximum string voltage 1,500 V DC, maximum Isc per string 20 A. Connection of a 5-pole control cable (5x 1.5 mm ²) to included connector (customer-provided cable). 4 mounting lugs included.
Q-510616	QFire Big HV - 20 A* Switching Unit for 16 PV Strings* Remote-controlled switching unit "QFire" for disconnecting 16 PV strings. 16 inputs (16x + 16x -), 16 outputs (16x + 16x -). Housing made of polycarbonate, IP 66/67, for installation in weather-protected outdoor areas, 300 x 300 mm (may be larger with additional components). String input and output connections via Stäubli MC4 EVO2 connectors (others on request). Maximum string voltage 1,500 V DC, maximum Isc per string 20 A. Connection of a 5-pole control cable (5x 1.5 mm ²) to included connector (customer-provided cable). 4 mounting lugs included.



Q-510618	QFire Big HV - 20 A* Switching Unit for 18 PV Strings* Remote-controlled switching unit "QFire" for disconnecting 18 PV strings. 18 inputs (18x + 18x -), 18 outputs (18x + 18x -). Steel enclosure, IP66, for installation in weather-protected outdoor areas, 600 x 600 mm (may be larger with additional components). String connection input and output via cable exits with Stäubli MC4 EVO2 connectors (other connector systems on request). Cable lengths: approx. 20 cm on the input side, approx. 40 cm on the output side (other lengths on request). Maximum string voltage 1,500 V DC, maximum Isc per string 20 A. Connection of a 5-pole control cable (5x 1.5 mm ²) to included connector (customer-provided cable). 4 mounting holes with 9 mm diameter for M8 screws
Q-510620	QFire Big HV - 20 A* Switching Unit for 20 PV Strings* Remote-controlled switching unit "QFire" for disconnecting 20 PV strings. 20 inputs (20x + 20x -), 20 outputs (20x + 20x -). Steel enclosure, IP66, for installation in weather-protected outdoor areas, 600 x 600 mm (may be larger with additional components). String connection input and output via cable exits with Stäubli MC4 EVO2 connectors (other connector systems on request). Cable lengths: approx. 20 cm on the input side, approx. 40 cm on the output side (other lengths on request). Maximum string voltage 1,500 V DC, maximum Isc per string 20 A. Connection of a 5-pole control cable (5x 1.5 mm ²) to included connector (customer-provided cable). 4 mounting holes with 9 mm diameter for M8 screws.
Q-510622	QFire Big HV - 20 A* Switching Unit for 22 PV Strings* Remote-controlled switching unit "QFire" for disconnecting 22 PV strings. 22 inputs (22x + 22x -), 22 outputs (22x + 22x -). Steel enclosure, IP66, for installation in weather-protected outdoor areas, 600 x 600 mm (may be larger with additional components). String connection input and output via cable exits with Stäubli MC4 EVO2 connectors (other connector systems on request). Cable lengths: approx. 20 cm on the input side, approx. 40 cm on the output side (other lengths on request). Maximum string voltage 1,500 V DC, maximum Isc per string 20 A. Connection of a 5-pole control cable (5x 1.5 mm ²) to included connector (customer-provided cable). 4 mounting holes with 9 mm diameter for M8 screws.
Q-510624	QFire Big HV - 20 A* Switching Unit for 24 PV Strings* Remote-controlled switching unit "QFire" for disconnecting 24 PV strings. 24 inputs (24x + 24x -), 24 outputs (24x + 24x -). Steel enclosure, IP66, for installation in weather-protected outdoor areas, 600 x 600 mm (may be larger with additional components). String connection input and output via cable exits with Stäubli MC4 EVO2 connectors (other connector systems on request). Cable lengths: approx. 20 cm on the input side, approx. 40 cm on the output side (other lengths on request). Maximum string voltage 1,500 V DC, maximum Isc per string 20 A. Connection of a 5-pole control cable (5x 1.5 mm ²) to included connector (customer-provided cable). 4 mounting holes with 9 mm diameter for M8 screws.
Accessories	
Article-No.	Product Description
Q-502102	Control Unit for integration into Big Box.
Q-595012	Surge protection T1/2 combination arrester with remote signalling contact for integration in the Q Fire
100574	Fuse + fuseholder in positive pole
100575	Fuse + fuseholder in negative pole
991010	Delay circuit for QFire* . Shutdown delay: 1 second per box in series. Pre-assembled and pre-tested PCB with connection tabs.
500666	QFire Power Patcher for connection to a control box. Enables data transmission to the Q3 Cloud via TCP/IP through the customer's router. Provides monitoring of: System status, Operating state (ON/OFF)
X50666	Reduction of a string



External Switches	
Article-No.	Product Description
500001	QFire emergency stop switch , surface-mounted
500003	QFire key switch , surface-mounted
500005	QFire emergency stop switch , surface-mounted, behind glas
500005_S	QFire key accessory for emergency stop switch behind glass (article number: 500005)



4 Installation



Observe the safety regulations according to chapter 1 SAFETY INSTRUCTIONS



In the event of improper or non-professional installation, there is a risk of electric shock, of a fire as well as damage to the product and the connected components!

4.1 Installation Point

Install the switch box(es) and control box at a load-bearing location (rack/wall). The installation point must be chosen in such a way that the boxes.

- are not directly be exposed to the weather.
- are not directly be exposed to the sunlight and are shaded as much as possible.
- are not additionally be heated up by e.g. machines close by.

Operating temperature must be complied with a range of -15°C to $+60^{\circ}\text{C}$.

The switch boxes can be attached to the substructure/frame under the PV modules, for example.



Risk of lethal electronic strike

With tendency to thunderstorms do not carry out work on the roof nor electrical wiring on the roof / in the house.



Danger when working at heights!

Observe the generally applicable health and safety and accident prevention regulations as well as the official regulations and guidelines for working at heights. Only use ladders, scaffolding and lifting platforms in accordance with the health and safety regulations!

Falling parts can endanger persons. Secure the danger zone inside and outside!



4.2 Mounting

The control box/switch box(es) are attached with the appropriate mounting ears (included).



When tightening the screws, keep in mind, that the housing (standard version) is made of plastic material – polycarbonate. Only use suitable tools.



Before start-up, check the complete system for hazards!

4.3 Connections



Lethal electric shock for people and animals when touching live parts of the electrical equipment including the connection terminals. Parts of the electrical equipment may be energized as intended, e.g. electrical conductors. Other parts of the QFire system may be revised if they become current-carrying in the event of a fault, e.g. if a damaged earthing cable sets parts under voltage.

Proceed as follows:

- 1. Interconnect the control box with the 1. switch box and further switch boxes with a control line cable 5 x 1.5 (2.5) mm² on site 1:1.**
 - See chapter 4.3.1 CONTROL LINES OF THE QFire-SYSTEM
- 2. Both, control box as well as switch box(es) must be connected to 230 VAC.**
 - See chapter 4.3.2 POWER SUPPLY
 - With option surge protection device an appropriate grounding has to be installed.
 - According to chapter 4.3.2.3 CONNECTION OF PE
- 3. Check QFire system function – PV strings not connected to switch box – as follows:**
 - Turn on the control box mains switch → all LEDs light up green.
 - See chapter 2.4.2 TURNING-ON MANUALLY
 - Measure the transmission at the MC4 plugs between input and output of the corresponding strings (coded) at the switch box → low impedance.
 - Turn off the control box mains switch → all LEDs off.
 - See chapter 2.4.3 TURNING-OFF MANUALLY



→ Measure the transmission at the MC4 plugs between input and output of the corresponding strings (coded) at the switch box → high impedance.

4. Connect the string lines to the switch box(es).

- According to chapter 4.3.3 PV STRING LINES TO SWITCH BOX

5. Perform a functional test with PV generator and inverter(s).

- According chapter 5 START-UP



[A mounting instruction of the Wieland plugs can be downloaded from our website](#)

4.3.1 Control Lines of the QFire System

The QFire system is supplied with plug-and-play connectors for the control wiring.

This innovation has been developed to make the installation of the fireman’s switch as simple and efficient as possible. The core of this concept is the use of pre-wired, application-specific connectors for the control line.

As a result, the control cable between the control box and the switch box – and, if applicable, between additional switch boxes – no longer needs to be terminated on internal terminals within the enclosure.

The installer only needs to assemble the supplied mating connectors onto the on-site control cable and connect them to the control box and switch box.

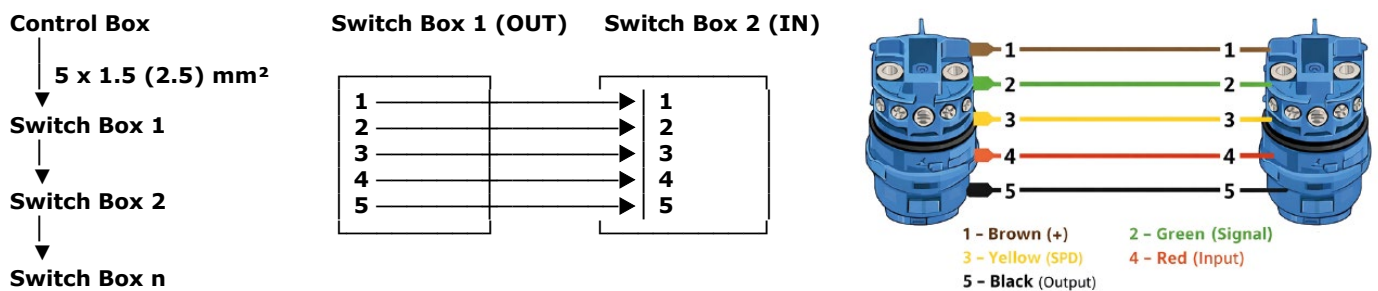

⚠ Conductors are connected 1:1 – no cross-wiring!

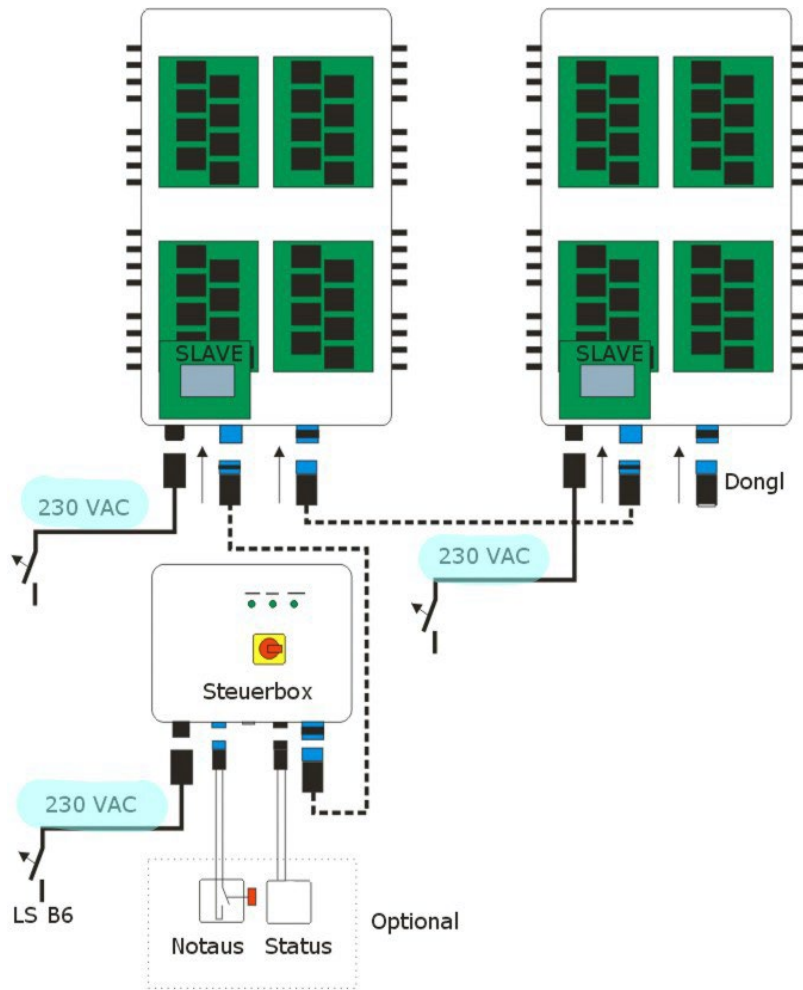

Figure 15: Control lines at switch box(es)



Control cables must be routed separately from other cables and must not be installed near potential sources of interference (e.g. high-power electric motors).



4.3.2 Power Supply

4.3.2.1 Power Supply Control Box

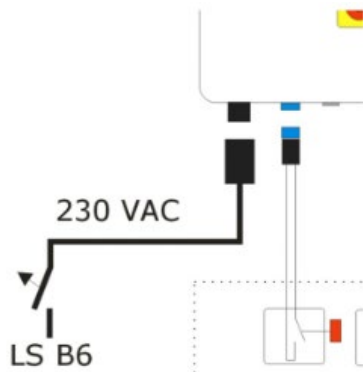

For power supply connection, use the supplied plug to connect to 230 VAC and secure the supply line with a B6 line protector.

Within the delivery content:
1 each Wieland plug RST08 (incl. allen key for lockable plug)



[A mounting instruction of the Wieland plugs can be downloaded from our website](#)

4.3.2.2 Power Supply Switch Box

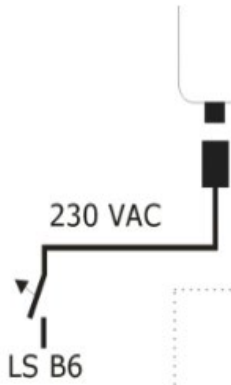

For power supply connection, use the supplied plug to connect to 230 VAC and secure the supply line with a B6 line protector.

Within the delivery content:
1 each Wieland plug RST08 (incl. allen key for lockable plug)



[A mounting instruction of the Wieland plugs can be downloaded from our website](#)



Control cables must be routed separately from other cables and must not be installed near potential sources of interference (e.g. high-power electric motors).



4.3.2.3 Connection of PE



On site a separate PE ground conductor 16 mm² must be installed into each switch box. Place on the provided clamp.

4.3.3 PV String Lines to Switch Box

Proceed as follows:

1. Turn off the control box mains switch OFF „0“.
2. Connect PV strings to the MC4 plugs of the switch box(es), see figure 16:
 - left – connection PV strings coming from PV modules
 - right – connection to the inverter



Observe the instructions in the manufacturer's descriptions!



Pay attention to the polarity and correct assignment of the PV strings!
Caution: Never connect strings of different lengths to the same MPP tracker. There is a risk of damage to the system, inverters and other installed components. When plugs are disconnected, an arc could occur!

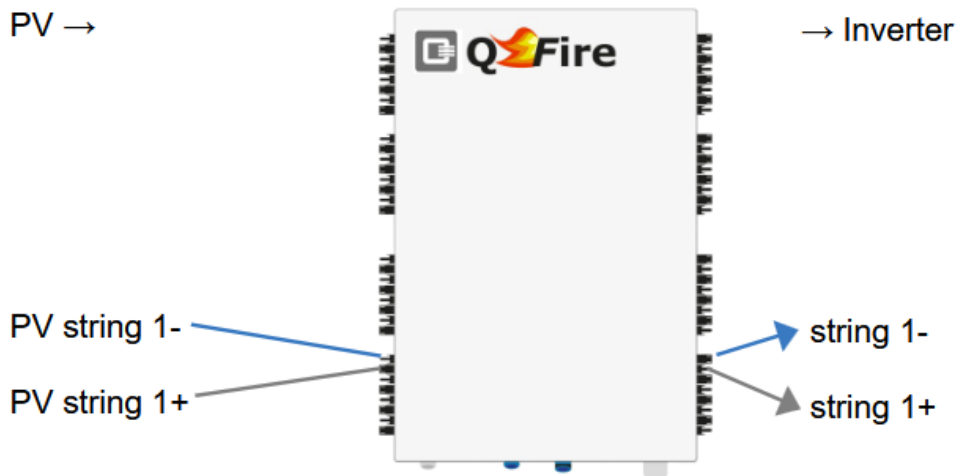

Figure 16: Connections switch box

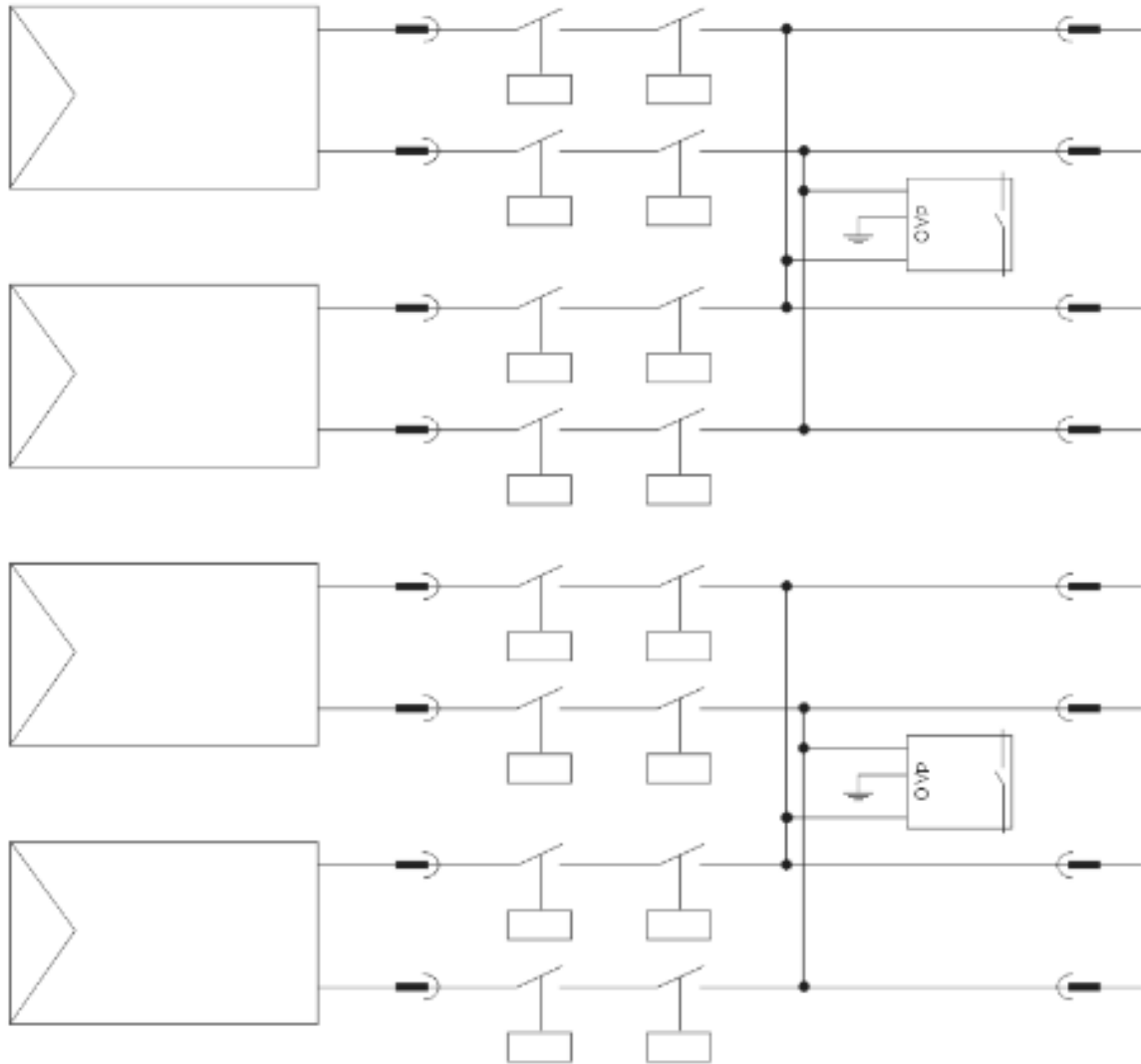

Figure 17: Interconnection PV strings and surge protection device SPD



4.3.4 Status Contact on the Control Box

The status signal provides the position of the main switch S1 of the control box via a potential-free contact:

Control box switched OFF (0) = potential-free contact open
Control box switched ON (1) = potential-free contact closed

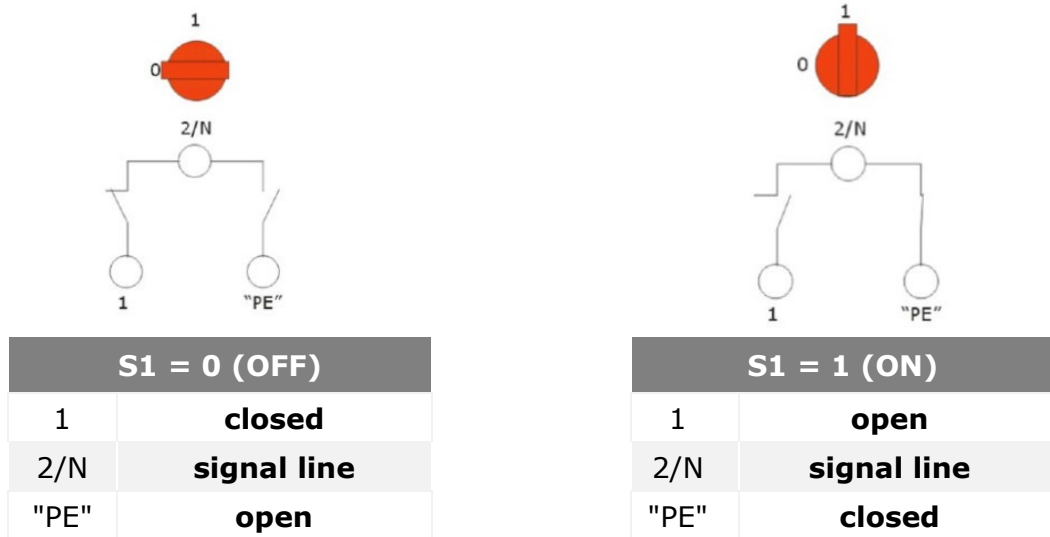

Figure 18: Switch position of mains switch S1: off 0 / on 1



ATTENTION

The indications **2/N** and **PE** on the mains switch **S1** are only contact markings and do not indicate to connect **230 VAC**.



4.3.4.1 Control of a Grid Protection Device (NA Protection) for Simultaneous AC Disconnection

What is the purpose? In hybrid systems (PV systems with a battery connected to the inverter), the DC link of the inverter may remain energized by the battery. As a result, in unfavourable conditions, a voltage to earth may still be present on the DC string cables even after DC-side disconnection.

For such systems, it is strongly recommended to disconnect the AC supply of the inverter simultaneously. This can be implemented most easily using the status contact of the control box.

Using the status contact (volt-free contact, NC or NO), an enable signal for a grid protection device (NA protection) or a corresponding input on the inverter can be controlled.

Example wiring using the ZIEHL UFR1001E:

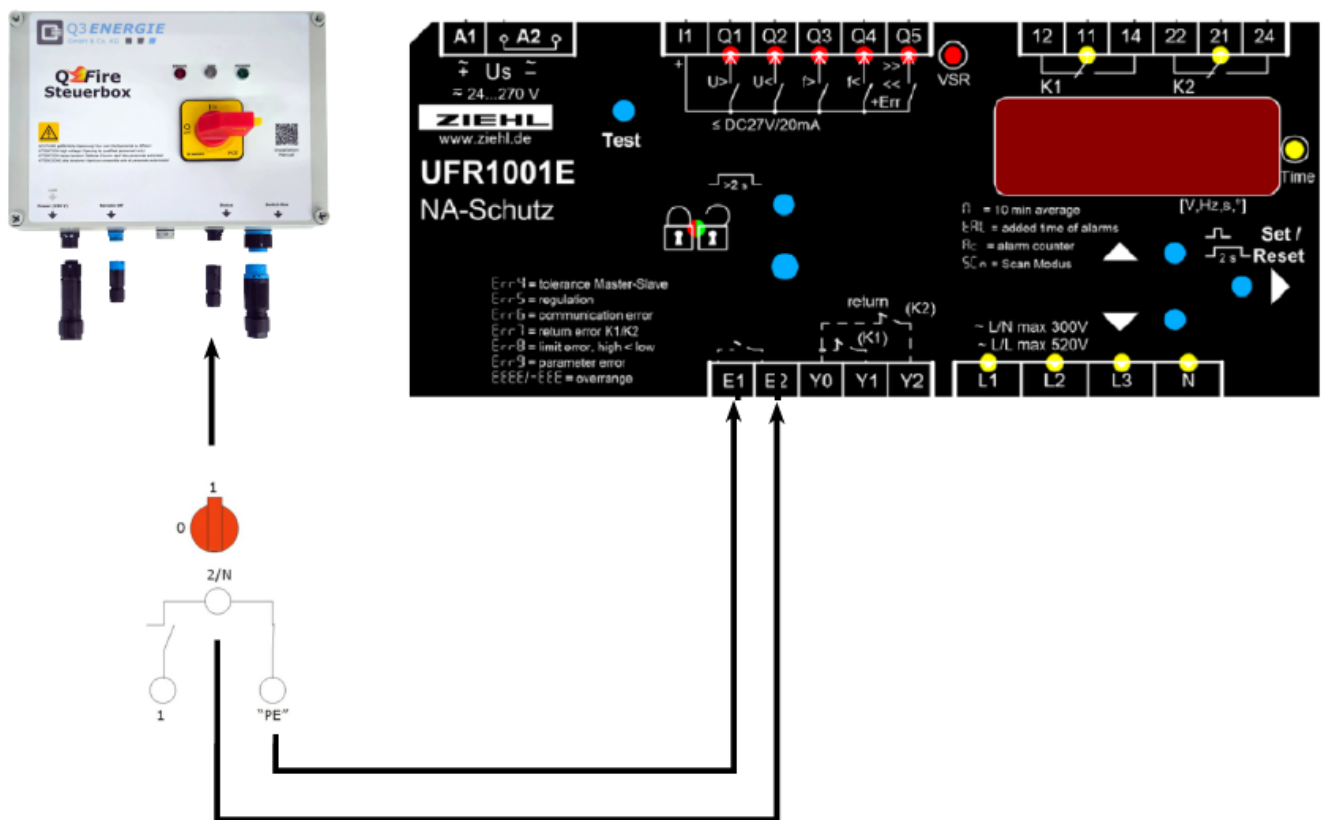

Contact 10 "Status" on the control box

Normally open (NO contact):

2 / N – PE connected in series to E1 – E2 (ZIEHL)



4.3.5 Optional Connections

4.3.5.1 Potential-Free Status Contact of SPD

Evaluation of the remote signaling contact is possible by using the optional additional plug on the control box for sending a potential-free signal:



plug on request
not included in standard delivery content

1. Switch-off the control box „0“.
2. A 2-wire cable 0.5 mm² must be connected to the included mating connector. The switching contacts of the relay K1 are transferred to pin1 and pin2.
3. Plug mating connector to the control box and switch on control box „I“.
4. LED SPD green: contact closed
LED SPD red: contact open

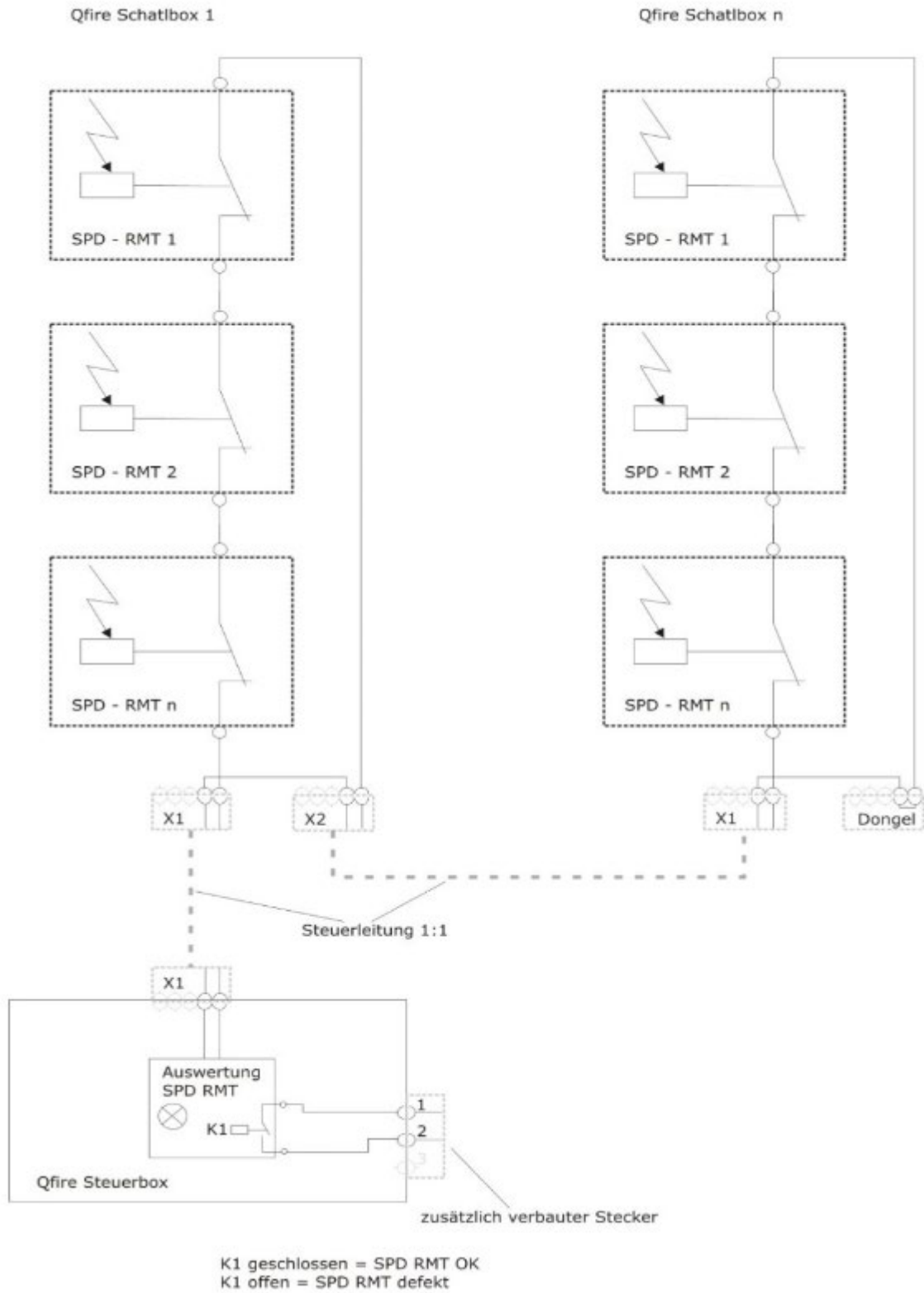
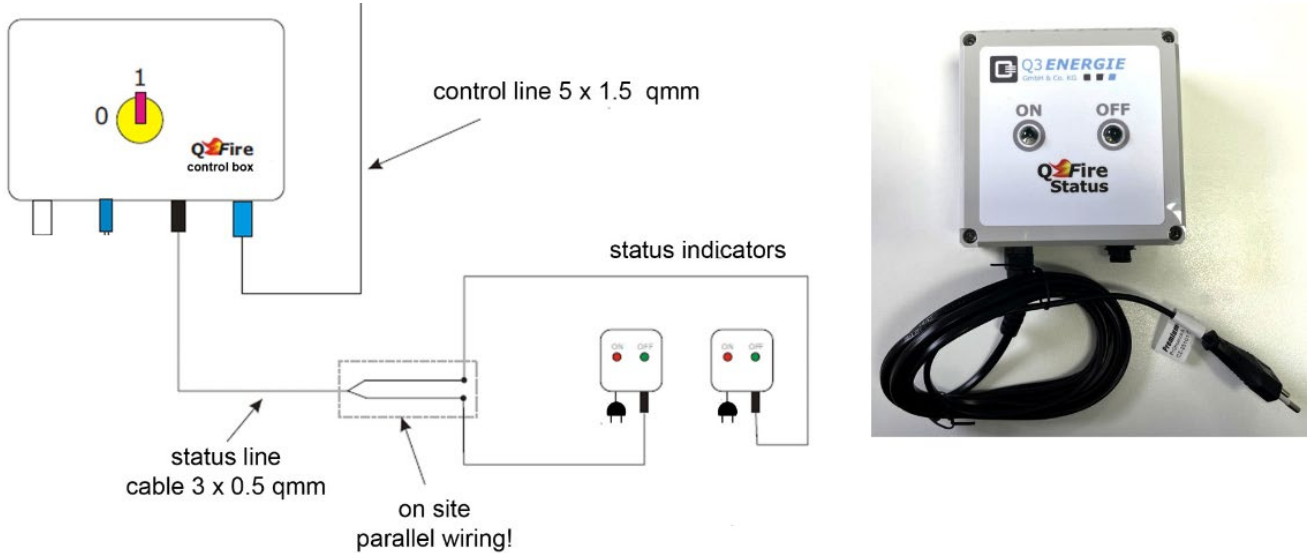

Figure 19: Schematics SPD RMT



4.3.5.2 External Status Indicators

The status of the QFire system can optionally/additionally be displayed visually via status indicators with LEDs red/green. Each status indicator box must be connected to a power socket.



LED Description	
green	PV generator switched off → no dangerous power from PV modules
red	PV generator is active → DANGER high voltage

4.3.5.3 External Emergency Switch

Functionality

! Without connection of the optional emergency stop, the bridge inside the connector **MUST** be set (see figures 2 and 7). Otherwise the system QFire will not get in operation.

! With connection of the optional emergency stop, the bridge (see figure 7) will be removed and cables mounted.

(The option emergency switch will be delivered with an already bridged 2-wire connection cable, see chapter 3.2 PARTS LIST)

3 Switch-off variants are available, (see also illustrations in chapter 2.1.2 OPTIONAL EMERGENCY STOP).



	PV generator switched off	reactivation of PV generator
Emergency stop push button	Press it until it clicks into place.	Turn it to unlatch.
Emergency stop button behind glass	Smash the glass and press stop button.	<ol style="list-style-type: none">1. Open housing with key (see 3.2 PARTS LIST).2. Operate release latch.
Emergency stop key switch	Turn key switch to position 0 and pull off the key for protection purpose. (Avoiding restarting during fire extinguishing work.)	Insert the key and turn the key switch to position 1. (The key can no longer be removed in this position..)

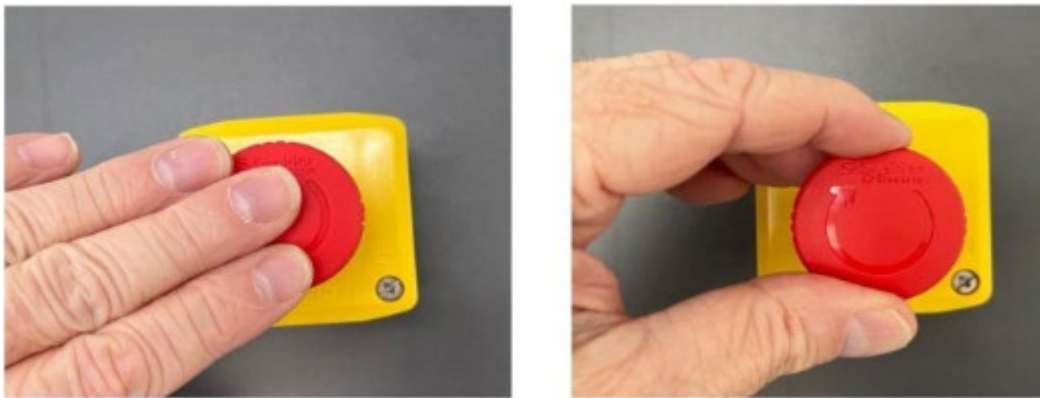

Figure 20: Sequence for reactivation of emergency stop push button



Figure 21: Sequence for reactivation of emergency stop button behind glass



Figure 22: Sequence for reactivation of key switch

Connection:

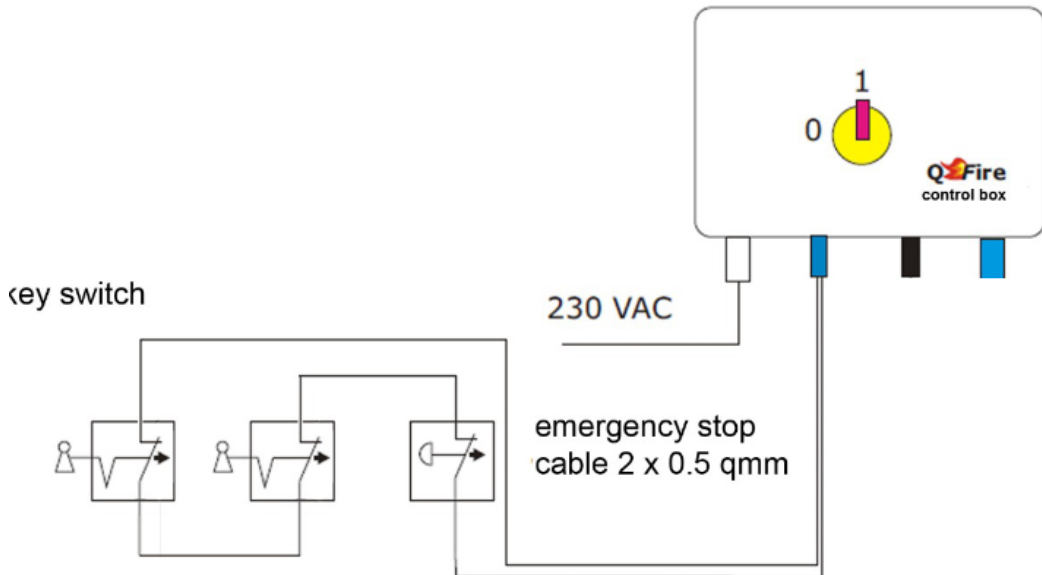

Figure 23: Cabeling key switch



Figure 24: Cabeling emergency stop



5 START-UP



Start-up may only be carried out by qualified electricians with PV electrical knowledge!



People who work or stay in near the QFire product, are to be informed about the possible dangers of PV system components.



Start-up is recommended during the day (sunlight) and in suitable weather (non-snow-covered modules) in order to be able to test the function properly.

Proceed as follows:

- 1. Connect all control lines on control box and switch box(es).**
 - See chapter 4.3 CONNECTIONS
- 2. Turn on the QFire system via control box mains switch S1 „on“ = „1“.**
 - See chapter 2.4.2 TURNING-ON MANUALLY, page 15.
- 3. If everything is wired correctly and all connected switch boxes have contacted through, the green POWER LED at the control box lights up.**
 - See chapter 2.4.1 LED STATUS INDICATION, page 14.
- 4. Now the PV generator voltage is applied to the inverter(s) and they should start working after their self-test and grid-test (if the sun is shining).**
- 5. With the Surge Protection Device option installed, the SPD LED at the control box must light up green.** (If no surge protection is installed, SPD LED is not present.)
 - See chapter 2.4.2.1 OPTIONAL MONITORING OF OVERVOLTAGE SPD, page 15.
- 6. After about 5 minutes, shut down the system voltage-free again by turning-off the mains switch S1 at the control box „off“ = „0“.**
 - According to chapter 2.4.3 TURNING-OFF MANUALLY, page 16.
 - All connected switch boxes must turning off at the same time. (Time-shifted shutdown with delay switching option according to chapter 2.4.3.2 OPTIONAL SHUTDOWN DELAY)
- 7. Now PV generator does not deliver voltage anymore. Check the voltage on the inverter(s).**

After 5 minutes at the latest, the display on the inverter(s) should show 0 VDC. (Refer to the inverter manual of the manufacturer in order to use the appropriate methode for rechecking the voltage-free status of 0 VDC.)

 - All strings up from the switch box right side (see figure 16) must now be voltage-free.



→ If the 0 VDC voltage absence cannot be determined on the inverter due to the design (e.g. because inverter has no display), the voltage-free status must be measured at the PV string cables.



Observe the safety regulations to avoid an electric shock or the generation of an electric arc! You should also observe the safety regulations in the inverter manufacturer's instruction manual.



If the AC side of the inverter has not been disconnected, the inverter can remain active.

8. Repeat this procedure from point 2. - 7.

9. After installation and start-up all housings must be closed, in case they have been opened.

→ It must be ensured that these cannot be opened by unauthorized persons!

10. The installer specialist company issues a installation protocol and sends it with system data (serial number of the control box, installation company and installation address) to Q3 *ENERGIE* GmbH & Co. KG via email to service@q3-energie.de.



6 Maintenance | Service



The operator of the QFire system is responsible for complying with and commissioning the prescribed maintenance and service intervals.

6.1 Maintenance Interval



Service and maintenance work may only be carried out by a specialist company.



Regular visual inspections of the components by the customer/operator are recommended, especially in case of abnormalities, see chapter 7 TROUBLESHOOTING AND REMEDY

The operation of the product in intended use does not require any special supervision. The QFire system does not contain any component inside the housings which need to be serviced or repaired.

In case of a malfunction, the system must be switched off and put out of operation by a qualified electrician. The installer company must be notified.

Interval Service Check

Yearly Functional Test

6.1.1 Functional Test

A complete functional test must be carried out and documented annually. At this the QFire system is switched off and all strings from the distance between the QFire switch box(es) and inverter(s) must be voltage-free tested and confirmed. See chapter 5 START-UP.



The functional test must be carried out by a qualified electrician.



If you have any questions, please contact our Technical Support by having your serial number ready, see chapter 6.3 TECHNICAL SUPPORT at service@q3-energie.de



6.2 Documents



Further documentation is available from our website: www.q3-energie.de.

6.3 Technical Support

In a service case please contact us:
Q3 Energie GmbH & Co. KG
phone: +49 (0)8341/9080 334
email: service@q3-energie.de



Service request

**Sometimes things don't go as planned - we all know that.
If one of our products does not work as expected, we are here to help.
Our service team will ensure that your enquiry is dealt with quickly and easily here: [Service Request Form](#)**



7 Troubleshooting and Remedy

Contact our service to troubleshoot faults and errors, see chapter 6.3 TECHNICAL SUPPORT, page 31.

Symptom	Possible Cause	Remedy (contact service)
QFire system cannot be turned on (control box mains switch '0' → '1')	AC mains supply interrupted	Establish mains supply
LED Power: off LED SPD: off LED Error: off	Emergency stop: - connector not plugged in - connector not bridged (if option not available) - wrongly installed as opener instead of closer	- Plug in emergency stop connector - Bridge the connector - Correct installation
LED Power: off LED SPD: red LED Error: red	Control line: - control line broken - undervoltage on control lines (system partly off)	- Check control lines and replace if needed - Install control lines ≤ 10 m or replace with correct length and diameter
LED Power: green LED SPD: red LED Error: off	SPD tripped due to overvoltage	- Shut down PV generator - Turn control box mains switch to 'off' (0) - Check all PV strings
	Control line error	- Check control lines - Check wiring
	SPD component in switch box defective	- Check SPD components in switch boxes (red LED) - Replace defective SPD block
LED Power: green LED SPD: red LED Error: red	Control line broken	Check cable and replace if necessary
Emergency stop does not work	Plug contact still bridged	Remove bridge contact
QFire system cannot be turned off (control box mains switch 'off', '0') (PV generator remains in operation)	QFire control box defective	- Deinstall control box - Bridge PV strings (temporary operation) - Replace control box



8 Certifications

8.1 CE Declaration of Conformity

			
			
<h1>EU-Konformitätserklärung</h1>			
Der Hersteller			
Q3 ENERGIE GmbH & Co. KG Moosmangstr. 8 87600 Kaufbeuren Deutschland		Kommanditgesellschaft: HRA 10466 / AG: Kempten Komplementärin: HRA 14116 Q3 Vermögensverwaltung GmbH /AG: Kempten Geschäftsführer: Thomas Neumann UID: DE298067511	
Tel.: +49 (0)8341 9080 334 email: info@q3-energie.de www.q3-energie.de			
erklärt hiermit, dass das folgende Produkt			
Produktbezeichnung:	QFire Feuerwehrscharter		
Modellbezeichnung:	QFire Steuerbox / QFire Schaltbox		
Baujahr:	ab 2023		
Produktbeschreibung:	Das Produkt schaltet PV Strings galvanisch getrennt durch Betätigen eines Schalters oder durch Wegfall der Versorgungsspannung (netzabhängig) auf der Ausgangsseite der Schaltbox spannungsfrei. Die maximale Systemspannung beträgt 1.500 VDC, der maximale Schaltstrom beträgt 20A bei 1.500 VDC.		
allen einschlägigen Bestimmungen der angewandten Rechtsvorschriften (nachfolgend) - einschließlich deren zum Zeitpunkt der Erklärung geltenden Änderungen - entspricht. Die alleinige Verantwortung für die Ausstellung dieser Konformitätserklärung trägt der Hersteller. Diese Erklärung bezieht sich nur auf die Anlage in dem Zustand, in dem sie in Verkehr gebracht wurde; vom Endnutzer nachträglich angebrachte Teile und/oder nachträglich vorgenommene Eingriffe bleiben unberücksichtigt. Folgende Rechtsvorschriften wurden angewandt:			
EMV-Richtlinie 2014/30/EU Niederspannungsrichtlinie 2014/35/EU EU Richtlinie Entsorgung WEEE II 2012/19/EU EU-Richtlinie RoHS 2011/65/EU			
Die Schutzziele folgender weiterer Rechtsvorschriften wurden eingehalten: IEC 60947-3:2020 in Verbindung mit IEC 60947-1:2020 (Lasttrennschaltung bis 1.500 VDC)			
Seite 1 von 2			
Q3 ENERGIE GmbH & Co. KG Moosmangstraße 8 87600 Kaufbeuren		Tel.: +49 (0)8341/9080 334 info@q3-energie.de www.q3-energie.de	
			
			



Folgende harmonisierte Normen wurden angewandt:

- EN IEC 61000-6-2:2019-02** Elektromagnetische Verträglichkeit (EMV) - Teil 6-2:
Fachgrundnormen - Störfestigkeit für Industriebereiche (IEC 61000-6-2:2016)
- EN IEC 61000-6-3:2021-03** Elektromagnetische Verträglichkeit (EMV) - Teil 6-3:
Fachgrundnormen - Störaussendung für Wohnbereich, Geschäfts-
und Gewerbebereiche sowie Kleinbetriebe (IEC 61000-6-3:2020)

Hierzu angewandte Basis-Standards gemäß EMV-Prüfbericht:

EN 55016-2-3, EN IEC 61000-3-2, EN 61000-3-3, EN 61000-4-2, EN IEC 61000-4-3,
EN 61000-4-4, EN 61000-4-5, EN 61000-4-6, EN 61000-4-8, EN IEC 61000-4-11

Folgende nationale oder internationale Normen (oder Teile/Klauseln daraus) und Spezifikationen wurden angewandt:

- IEC 61643-31:2018** Norm für Geräte, die an die DC-Energiekreise von PV-Installationen mit Spannungen bis zu 1 500 V angeschlossen werden
- EN 50539-11:2013** Überspannungsschutzgeräte SPD
- EN 62208:2011** Norm für Kunststoffgehäuse für Niederspannungsschaltgerätekombinationen
- EN 62852:2014** Norm für Steckverbinder für Gleichspannungsanwendungen in PV-Systemen
- VDE-AR-E 2100-712** VDE: Elektrische Sicherheit im Fall einer Brandbekämpfung

Bevollmächtigte Person für die Zusammenstellung der technischen Unterlagen:

Herr Thomas Neumann
Q3 ENERGIE GmbH & Co. KG
Moosmangstr. 8
D-87600 Kaufbeuren

Kaufbeuren, den 19.09.2024

Geschäftsführer: Thomas Neumann *IM Elektrotechnik*

Seite 2 von 2

Q3 ENERGIE GmbH & Co. KG Tel.: +49 (0)8341/9080 334
Moosmangstraße 8 info@q3-energie.de
87600 Kaufbeuren www.q3-energie.de



Q3 ENERGIE GmbH & Co. KG



8.2 Certificate of Compliance



Certificate of compliance

Applicant: Q3 Energie GmbH & Co. KG
Moosmangstr. 8
87600 Kaufbeuren
Germany

Product: Switch Disconnecter

Models: Q3 QFirePV-HV Standard
Q3 QFirePV-HV BIG

The certificate refers to the stated model(s) which passed the tests according to the applicable standard(s):

Applied rules and standards:

IEC 60947-3:2020 in conjunction with IEC 60947-1:2020

Low-voltage switchgear and controlgear – Part 3: Switches, disconnectors, switch-disconnectors and fuse-combination units

* environmental tests were excluded – see test report for further details

At the time of issue of this certificate, the safety concept of an aforementioned representative product corresponds to the valid safety specifications for the specified use in accordance with regulations.

Report number: 25TH0209-IEC60947-3_2
Certificate number: U25-0913

Certification Program: NSOP-0038-DEU-ZE-V02
Date of issue: 2025-10-02

Certification body

Accreditation



Domenik Koll
Head of Energy Systems Germany



Accredited certification body by Deutsche Akkreditierungsstelle GmbH (DAkkS) according to ISO/IEC 17065. The accreditation is valid only for the scope listed in the annex of the accreditation certificate D-ZE-12024-01-00. The Deutsche Akkreditierungsstelle GmbH (DAkkS) is signatory of the multilateral arrangements of EA, ILAC and IAF for mutual recognition.

Without the written consent of Bureau Veritas Consumer Products Services Germany GmbH excerpts of this certificate of conformity shall not be reproduced.

Bureau Veritas Consumer Products Services Germany GmbH
www.bureauveritas.de/unsere-services/produktzertifizierung
ZERT-0020-DEU-ZE-ES-V01/TEMP-0048-DEU-ZE-ES-V01

Businesspark A96
86842 Tuerkheim

certification.deu@bureauveritas.com
Certificate number U25-0913

1/2



Annex certificate of conformity No. U25-0913

Extract from test report 25TH0209-IEC60947-3_2 issued by a testing laboratory accredited by "Deutsche Akkreditierungsstelle GmbH (DAkkS)" according to ISO/IEC 17025. The accreditation is only valid for the scope listed in the annex of the accreditation certificate "D-PL-12024-03-02".

Type Approval and declaration of compliance with the requirements of IEC 60947-3:2020				
Manufacturer / applicant	Q3 Energie GmbH & Co. KG Moosmangstr. 8 87600 Kaufbeuren Germany			
Product type	Switch Disconnecter			
	Q3 QFirePV-HV Standard	Q3 QFirePV-HV Big	--	--
Input (DC)				
DC voltage range [V]	1500	1500	--	--
Max. DC current [A]	20	20	--	--



9 Technical Data

9.2 Control Box



QFire Control Box

for connection to QFire Switch Boxes Series BIG

Technical Data	
Connections	Wieland (required mating connectors included)
Standards	CE (control of a QFire switch box for disconnection of PV systems according to IEC 60947-3)
Enclosure (incl. mounting flanges)	
Material	Polycarbonat
IP Rating (EN60529)	IP 66/67
Impact Resistance	IK08 (+35°C/-25°C)
Certification	EN 62208:2011:2011
Mounting Location	Protected outdoor area
Dimensions (L × W × H mm)	250 × 175 × 100
Weight	approx. 1.1 kg
Voltage	
Operating Voltage	230 VAC
Fuse	B6 circuit protection
Power Data	approx. 40 mA at 230 VAC
Control Voltage	24 V DC (12 V DC)
Communication	Status indication via LEDs (LAN / Ethernet optional)
Operating Temperature	-25 °C to +50 °C
Humidity	0 – 99 % RH (non-condensing)
Options	External key switch or emergency stop, potential-free contact (signal for status indication or AC-side disconnection)

9.3 Cluster Control Box



QFire Cluster Control Box

for connection to QFire Switch Boxes Series BIG

Technical Data	
Connections	Wieland (required mating connectors included)
Standards	CE (control of a QFire switch box for disconnection of PV systems according to IEC 60947-3)
Enclosure (incl. mounting flanges)	
Material	Polycarbonat
IP Rating (EN60529)	IP 66/67
Impact Resistance	IK08 (+35°C/-25°C)
Certification	EN 62208:2011:2011
Mounting Location	Protected outdoor area
Dimensions (L × W × H mm)	250 × 175 × 100
Weight	approx. 1.1 kg
Voltage	
Operating Voltage	230 VAC
Fuse	B6 circuit protection
Power Data	approx. 40 mA at 230 VAC
Control Voltage	24 V DC (12 V DC)
Communication	Status indication via LEDs (LAN / Ethernet optional)
Operating Temperature	-25 °C to +50 °C
Humidity	0 – 99 % RH (non-condensing)
Options	External key switch or emergency stop, potential-free contact (signal for status indication or AC-side disconnection)



9.4 Switch Box 2 Strings



Q-510602 Switching Unit for up to 2 Strings acc. to IEC 60947-3

Technical Data			
Switching method	galvanic isolation		
Connections	Stäubli MC4-Evo 2 (compatible with all MC4) 4–6 mm ² optional clamping technology		
Number of strings	modularly expandable with 1–∞ switch boxes		
Standards	CE, IEC 60947-3, suitable for VDE-AR-E 2100-712		
Enclosure			
Material	Polycarbonate	Colour	grey, cover grey or transparent
Impact resistance	IK10 (+60°C/-25°C)	Protection class	IP 66
Installation site	Protected outdoor area	Certification	EN 62208:2011
Dimensions (L x W x D, mm)	300 x 400 x 132 (may be larger with additional components)	Weight	approx. 2 kg (depending on equipment)
AC (via integrated control unit, item Q-502102)			
Operating voltage	230 VAC for control unit	Fuse	B6 circuit breaker
Power consumption	< 100 W		
DC Connection			
Number of strings	2	Isc max	20 A per string
Switching voltage max. at 20 A	1,500 V DC		
Surge Protection (integrated, optional)			
Category	DC T1+2	Remote signalling contact	yes
Compliance	IEC 61634-31:2018, EN 50539-111:2012+A1:2014	Maximum discharge capacity (Imax)	40 kA
Communication	Status indication via optical LEDs		
Operating conditions	-25 °C to +50 °C		
Humidity	0–99% relative humidity (non-condensing)		

9.5 Switch Box 4 Strings



Q-510604 Switching Unit for up to 4 Strings acc. to IEC 60947-3

Technical Data			
Switching method	galvanic isolation		
Connections	Stäubli MC4-Evo 2 (compatible with all MC4) 4–6 mm ² optional clamping technology		
Number of strings	modularly expandable with 1–∞ switch boxes		
Standards	CE, IEC 60947-3, suitable for VDE-AR-E 2100-712		
Enclosure			
Material	Polycarbonate	Colour	grey, cover grey or transparent
Impact resistance	IK10 (+60°C/-25°C)	Protection class	IP 66
Installation site	Protected outdoor area	Certification	EN 62208:2011
Dimensions (L x W x D, mm)	300 x 400 x 132 (may be larger with additional components)	Weight	approx. 3 kg (depending on equipment)
AC (via integrated control unit, item Q-502102)			
Operating voltage	230 VAC for control unit	Fuse	B6 circuit breaker
Power consumption	< 100 W		
DC Connection			
Number of strings	4	Isc max	20 A per string
Switching voltage max. at 20 A	1,500 V DC		
Surge Protection (integrated, optional)			
Category	DC T1+2	Remote signalling contact	yes
Compliance	IEC 61634-31:2018, EN 50539-111:2012+A1:2014	Maximum discharge capacity (Imax)	40 kA
Communication	Status indication via optical LEDs		
Operating conditions	-25 °C to +50 °C		
Humidity	0–99% relative humidity (non-condensing)		



9.6 Switch Box 6 Strings



Q-510606 Switching Unit for up to 6 Strings acc. to IEC 60947-3

Technical Data			
Switching method	galvanic isolation		
Connections	Stäubli MC4-Evo 2 (compatible with all MC4) 4–6 mm ² optional clamping technology		
Number of strings	modularly expandable with 1–∞ switch boxes		
Standards	CE, IEC 60947-3, suitable for VDE-AR-E 2100-712		
Enclosure			
Material	Polycarbonate	Colour	grey, cover grey or transparent
Impact resistance	IK10 (+60°C/-25°C)	Protection class	IP 66
Installation site	Protected outdoor area	Certification	EN 62208:2011
Dimensions (L x W x D, mm)	300 x 400 x 132 (may be larger with additional components)	Weight	approx. 4 kg (depending on equipment)
AC (via integrated control unit, item Q-502102)			
Operating voltage	230 VAC for control unit	Fuse	B6 circuit breaker
Power consumption	< 100 W		
DC Connection			
Number of strings	6	Isc max	20 A per string
Switching voltage max. at 20 A	1,500 V DC		
Surge Protection (integrated, optional)			
Category	DC T1+2	Remote signalling contact	yes
Compliance	IEC 61634-31:2018, EN 50539-111:2012+A1:2014	Maximum discharge capacity (Imax)	40 kA
Communication	Status indication via optical LEDs		
Operating conditions	-25 °C to +50 °C		
Humidity	0–99% relative humidity (non-condensing)		

9.7 Switch Box 8 Strings



Q-510608 Switching Unit for up to 8 Strings acc. to IEC 60947-3

Technical Data			
Switching method	galvanic isolation		
Connections	Stäubli MC4-Evo 2 (compatible with all MC4) 4–6 mm ² optional clamping technology		
Number of strings	modularly expandable with 1–∞ switch boxes		
Standards	CE, IEC 60947-3, suitable for VDE-AR-E 2100-712		
Enclosure			
Material	Polycarbonate	Colour	grey, cover grey or transparent
Impact resistance	IK10 (+60°C/-25°C)	Protection class	IP 66
Installation site	Protected outdoor area	Certification	EN 62208:2011
Dimensions (L x W x D, mm)	300 x 400 x 132 (may be larger with additional components)	Weight	approx. 5 kg (depending on equipment)
AC (via integrated control unit, item Q-502102)			
Operating voltage	230 VAC for control unit	Fuse	B6 circuit breaker
Power consumption	< 100 W		
DC Connection			
Number of strings	8	Isc max	20 A per string
Switching voltage max. at 20 A	1,500 V DC		
Surge Protection (integrated, optional)			
Category	DC T1+2	Remote signalling contact	yes
Compliance	IEC 61634-31:2018, EN 50539-111:2012+A1:2014	Maximum discharge capacity (Imax)	40 kA
Communication	Status indication via optical LEDs		
Operating conditions	-25 °C to +50 °C		
Humidity	0–99% relative humidity (non-condensing)		



9.8 Switch Box 10 Strings



Q-510610 Switching Unit for up to 10 Strings acc. to IEC 60947-3

Technical Data			
Switching method	galvanic isolation		
Connections	Stäubli MC4-Evo 2 (compatible with all MC4) 4–6 mm ² optional clamping technology		
Number of strings	modularly expandable with 1–∞ switch boxes		
Standards	CE, IEC 60947-3, suitable for VDE-AR-E 2100-712		
Enclosure			
Material	Sheet steel	Colour	grey
Impact resistance	IK10 (+60°C/-25°C)	Protection class	IP 66
Installation site	Protected outdoor area	Certification	EN 62208:2011
Dimensions (L x W x D, mm)	600 x 600 x 200 (may be larger with additional components)	Weight	approx. 6 kg (depending on equipment)
AC (via integrated control unit, item Q-502102)			
Operating voltage	230 VAC for control unit	Fuse	B6 circuit breaker
Power consumption	< 100 W		
DC Connection			
Number of strings	10	Isc max	20 A per string
Switching voltage max. at 20 A	1,500 V DC		
Surge Protection (integrated, optional)			
Category	DC T1+2	Remote signalling contact	yes
Compliance	IEC 61634-31:2018, EN 50539-111:2012+A1:2014	Maximum discharge capacity (Imax)	40 kA
Communication	Status indication via optical LEDs		
Operating conditions	-25 °C to +50 °C		
Humidity	0–99% relative humidity (non-condensing)		

9.9 Switch Box 12 Strings

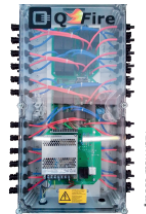

Q-510612 Switching Unit for up to 12 Strings acc. to IEC 60947-3

Technical Data			
Switching method	galvanic isolation		
Connections	Stäubli MC4-Evo 2 (compatible with all MC4) 4–6 mm ² optional clamping technology		
Number of strings	modularly expandable with 1–∞ switch boxes		
Standards	CE, IEC 60947-3, suitable for VDE-AR-E 2100-712		
Enclosure			
Material	Polycarbonate	Colour	grey, cover grey or transparent
Impact resistance	IK10 (+60°C/-25°C)	Protection class	IP 66
Installation site	Protected outdoor area	Certification	EN 62208:2011
Dimensions (L x W x D, mm)	300 x 600 x 132 (may be larger with additional components)	Weight	approx. 8 kg (depending on equipment)
AC (via integrated control unit, item Q-502102)			
Operating voltage	230 VAC for control unit	Fuse	B6 circuit breaker
Power consumption	< 100 W		
DC Connection			
Number of strings	12	Isc max	20 A per string
Switching voltage max. at 20 A	1,500 V DC		
Surge Protection (integrated, optional)			
Category	DC T1+2	Remote signalling contact	yes
Compliance	IEC 61634-31:2018, EN 50539-111:2012+A1:2014	Maximum discharge capacity (Imax)	40 kA
Communication	Status indication via optical LEDs		
Operating conditions	-25 °C to +50 °C		
Humidity	0–99% relative humidity (non-condensing)		



9.10 Switch Box 14 Strings

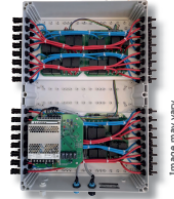

Q-510614 Switching Unit for up to 14 Strings acc. to IEC 60947-3

Technical Data			
Switching method	galvanic isolation		
Connections	Stäubli MC4-Evo 2 (compatible with all MC4) 4–6 mm ² optional clamping technology		
Number of strings	modularly expandable with 1–∞ switch boxes		
Standards	CE, IEC 60947-3, suitable for VDE-AR-E 2100-712		
Enclosure			
Material	Polycarbonate	Colour	grey, cover grey or transparent
Impact resistance	IK10 (+60°C/-25°C)	Protection class	IP 66
Installation site	Protected outdoor area	Certification	EN 62208:2011
Dimensions (L x W x D, mm)	400 x 600 x 132 (may be larger with additional components)	Weight	approx. 10 kg (depending on equipment)
AC (via integrated control unit, item Q-502102)			
Operating voltage	230 VAC for control unit	Fuse	B6 circuit breaker
Power consumption	< 100 W		
DC Connection			
Number of strings	14	Isc max	20 A per string
Switching voltage max. at 20 A	1,500 V DC		
Surge Protection (integrated, optional)			
Category	DC T1+2	Remote signalling contact	yes
Compliance	IEC 61634-31:2018, EN 50539-111:2012+A1:2014	Maximum discharge capacity (Imax)	40 kA
Communication	Status indication via optical LEDs		
Operating conditions	-25 °C to +50 °C		
Humidity	0–99% relative humidity (non-condensing)		

9.11 Switch Box 16 Strings

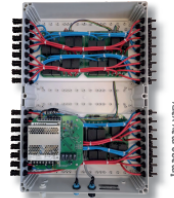

Q-510616 Switching Unit for up to 16 Strings acc. to IEC 60947-3

Technical Data			
Switching method	galvanic isolation		
Connections	Stäubli MC4-Evo 2 (compatible with all MC4) 4–6 mm ² optional clamping technology		
Number of strings	modularly expandable with 1–∞ switch boxes		
Standards	CE, IEC 60947-3, suitable for VDE-AR-E 2100-712		
Enclosure			
Material	Polycarbonate	Colour	Grey, cover grey or transparent
Impact resistance	IK10 (+60°C/-25°C)	Protection class	IP 66/67
Installation site	Protected outdoor area	Certification	EN 62208:2011
Dimensions (L x W x D, mm)	400 x 600 x 132 (may be larger with additional components)	Weight	approx. 12 kg (depending on equipment)
AC (via integrated control unit, item Q-502102)			
Operating voltage	230 VAC for control unit	Fuse	B6 circuit breaker
Power consumption	< 100 W		
DC Connection			
Number of strings	16	Isc max	20 A per string
Switching voltage max. at 20 A	1,500 V DC		
Surge Protection (integrated, optional)			
Category	DC T1+2	Remote signalling contact	yes
Compliance	IEC 61634-31:2018, EN 50539-111:2012+A1:2014	Maximum discharge capacity (Imax)	40 kA
Communication	Status indication via optical LEDs		
Operating conditions	-25 °C to +50 °C		
Humidity	0–99% relative humidity (non-condensing)		



9.12 Switch Box 18 Strings



QFire·BIG·18

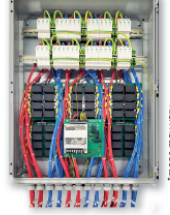

Q-510618 Switching Unit for up to 18 Strings acc. to IEC 60947-3

Technical Data			
Switching method	galvanic isolation		
Connections	Stäubli MC4-Evo 2 (compatible with all MC4) 4–6 mm ² optional clamping technology		
Number of strings	modularly expandable with 1–∞ switch boxes		
Standards	CE, IEC 60947-3, suitable for VDE-AR-E 2100-712		
Enclosure			
Material	Sheet steel	Colour	grey
Impact resistance	IK10 (+60°C/-25°C)	Protection class	IP 66
Installation site	Protected outdoor area	Certification	EN 62208:2011
Dimensions (L x W x D, mm)	600 x 600 x 200 (may be larger with additional components)	Weight	approx. 14 kg (depending on equipment)
AC (via integrated control unit, item Q-502102)			
Operating voltage	230 VAC for control unit	Fuse	B6 circuit breaker
Power consumption	< 100 W		
DC Connection			
Number of strings	18	Isc max	20 A per string
Switching voltage max. at 20 A	1,500 V DC		
Surge Protection (integrated, optional)			
Category	DC T1+2	Remote signalling contact	yes
Compliance	IEC 61634-31:2018, EN 50539-111:2012+A1:2014	Maximum discharge capacity (Imax)	40 kA
Communication	Status indication via optical LEDs		
Operating conditions	-25 °C to +50 °C		
Humidity	0–99% relative humidity (non-condensing)		

9.13 Switch Box 20 Strings



QFire·BIG·20

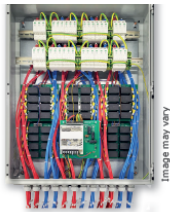

Q-510620 Switching Unit for up to 20 Strings acc. to IEC 60947-3

Technical Data			
Switching method	galvanic isolation		
Connections	Stäubli MC4-Evo 2 (compatible with all MC4) 4–6 mm ² optional clamping technology		
Number of strings	modularly expandable with 1–∞ switch boxes		
Standards	CE, IEC 60947-3, suitable for VDE-AR-E 2100-712		
Enclosure			
Material	Sheet steel	Colour	grey
Impact resistance	IK10 (+60°C/-25°C)	Protection class	IP 66
Installation site	Protected outdoor area	Certification	EN 62208:2011
Dimensions (L x W x D, mm)	600 x 600 x 200 (may be larger with additional components)	Weight	approx. 16 kg (depending on equipment)
AC (via integrated control unit, item Q-502102)			
Operating voltage	230 VAC for control unit	Fuse	B6 circuit breaker
Power consumption	< 100 W		
DC Connection			
Number of strings	20	Isc max	20 A per string
Switching voltage max. at 20 A	1,500 V DC		
Surge Protection (integrated, optional)			
Category	DC T1+2	Remote signalling contact	yes
Compliance	IEC 61634-31:2018, EN 50539-111:2012+A1:2014	Maximum discharge capacity (Imax)	40 kA
Communication	Status indication via optical LEDs		
Operating conditions	-25 °C to +50 °C		
Humidity	0–99% relative humidity (non-condensing)		



9.14 Switch Box 22 Strings

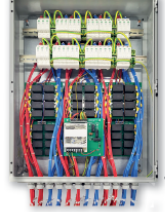

Q-510622 Switching Unit for up to 22 Strings acc. to IEC 60947-3

Technical Data			
Switching method	galvanic isolation		
Connections	Stäubli MC4-Evo 2 (compatible with all MC4) 4-6 mm ² optional clamping technology		
Number of strings	modularly expandable with 1-∞ switch boxes		
Standards	CE, IEC 60947-3, suitable for VDE-AR-E 2100-712		
Enclosure			
Material	Sheet steel	Colour	grey
Impact resistance	IK10 (+60°C/-25°C)	Protection class	IP 66
Installation site	Protected outdoor area	Certification	EN 62208:2011
Dimensions (L x W x D, mm)	600 x 600 x 200 (may be larger with additional components)	Weight	approx. 18 kg (depending on equipment)
AC (via integrated control unit, item Q-502102)			
Operating voltage	230 VAC for control unit	Fuse	B6 circuit breaker
Power consumption	< 100 W		
DC Connection			
Number of strings	22	Isc max	20 A per string
Switching voltage max. at 20 A	1,500 V DC		
Surge Protection (integrated, optional)			
Category	DC T1+2	Remote signalling contact	yes
Compliance	IEC 61634-31:2018, EN 50539-111:2012+A1:2014	Maximum discharge capacity (Imax)	40 kA
Communication	Status indication via optical LEDs		
Operating conditions	-25 °C to +50 °C		
Humidity	0-99% relative humidity (non-condensing)		

9.15 Switch Box 24 Strings

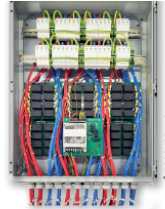

Q-510624 Switching Unit for up to 24 Strings acc. to IEC 60947-3

Technical Data			
Switching method	galvanic isolation		
Connections	Stäubli MC4-Evo 2 (compatible with all MC4) 4-6 mm ² optional clamping technology		
Number of strings	modularly expandable with 1-∞ switch boxes		
Standards	CE, IEC 60947-3, suitable for VDE-AR-E 2100-712		
Enclosure			
Material	Sheet steel	Colour	grey
Impact resistance	IK10 (+60°C/-25°C)	Protection class	IP 66
Installation site	Protected outdoor area	Certification	EN 62208:2011
Dimensions (L x W x D, mm)	600 x 600 x 200 (may be larger with additional components)	Weight	approx. 20 kg (depending on equipment)
AC (via integrated control unit, item Q-502102)			
Operating voltage	230 VAC for control unit	Fuse	B6 circuit breaker
Power consumption	< 100 W		
DC Connection			
Number of strings	24	Isc max	20 A per string
Switching voltage max. at 20 A	1,500 V DC		
Surge Protection (integrated, optional)			
Category	DC T1+2	Remote signalling contact	yes
Compliance	IEC 61634-31:2018, EN 50539-111:2012+A1:2014	Maximum discharge capacity (Imax)	40 kA
Communication	Status indication via optical LEDs		
Operating conditions	-25 °C to +50 °C		
Humidity	0-99% relative humidity (non-condensing)		



9.16 Q3 SPD

Technische Daten

Eigenschaften Elektrisch		Q3-PV1500
Maximale Betriebsspannung		1.500 VDC
Nominal Ableitstrom In (8/20 µs)		20 kA
Impuls Ableitstrom Iimp (10/350 µs)		6,25 kA
Ableitstrom Total (10/350 µs) Itotal		12,5 kA
Ableitstrom Total (8/20 µs) Itotal		40 kA
Maximaler Ableitstrom Imax		40 kA
Reaktionszeit tA		<25ns
Baustein Ableiter		High Energy MOV
Normen (Compliance)		IEC 61643-31:2018, CE, EN 50539-11:2013+A1:2014,
Zertifizierer		TÜV Rheinland
Status Anzeige		Fermmeldekontakt, Indikator grün/rot
Mechanik und Umgebung		Q3-PV1500
Umgebungstemperatur im Einsatz		-40° C ... 70° C
Luftfeuchtigkeit (nicht kondensierend)		5%...95%
Anzugsmoment		4,5 Nm
Schraubkontakte		2 AWG starr, 4 AWG flexibel
Montage		DIN Rail, 35mm, EN 60715
Gehäuse Material		Thermoplast, UL 94 V-0
Abmessungen l - b - t (mm)		54 - 90 - 81

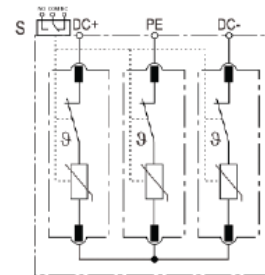
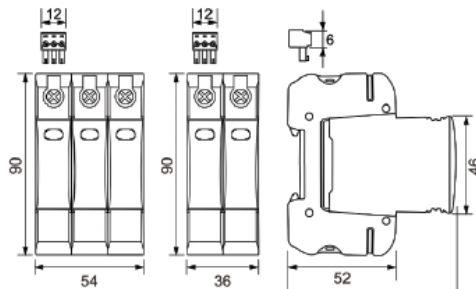



10 Disposal



The symbol of the "crossed-out garbage can" means that you are legally obliged to collect these devices separately from unsorted municipal waste.

Information on the disposal of electrical and electronic equipment in the European Community: Electrically operated equipment is disposed of in accordance with national rules based on the EU Directive 2002/96/EC on waste electrical and electronic equipment (WEEE). According to this, all devices delivered after 13.08.2005 may no longer be disposed of in municipal or household waste, but via special collection and return systems.

Options for returning old equipment: Owners of old appliances from private households can hand them in free of charge at the collection points of the public waste management authorities or at the take-back points set up by manufacturers or distributors within the meaning of the Electrical and Electronic Equipment Act. On the website of the foundation "elektro-altgeräte register" (www.e-ar-system.de) you will find a list of collection and take-back points.

Q3 *ENERGIE* is registered as a manufacturer of electrical and/or electronic equipment under the WEEE registration number DE 26170472 with the stiftung elektro-altgeräte register, Nordostpark 72, 90411 Nuremberg, Germany. Further information about disposal according to ElektroG is available on our website, see link: <https://q3-energie.de/ueber-die-q3/informationspflicht-nach-elektrog-novelliert/>

In our business with our suppliers and customers, our terms and conditions apply Q3 *ENERGIE* GmbH & Co. KG has prepared this document to the best of its knowledge and has made every effort to ensure that the information in this document is accurate. However, many factors beyond the current knowledge or control of Q3 *ENERGIE* GmbH & Co. KG may affect the use by the user or the operation of QFire. Q3 *ENERGIE* GmbH & Co. KG does not warrant that the document is free of errors or omissions. Furthermore, to the fullest extent possible, Q3 *ENERGIE* GmbH & Co. KG expressly disclaims any warranty as to the nature, integrity, merchantability or suitability of this document and limits liability for direct or consequential damages at the discretion of Q3 *ENERGIE* GmbH & Co. KG to a re-provision of the document or to the cost of correcting the document. Like all electrical products, Q3 *ENERGIE* GmbH & Co. KG products must be installed and operated correctly. You must ensure that you read, understand and follow the instructions – as well as any local laws or safety standards – and take reasonable care when installing or using Q3 *ENERGIE* GmbH & Co. KG products. If you do not understand the instructions or information in this document, please contact Q3 *ENERGIE* GmbH & Co. KG at the address below.

Copyright © 2024 Q3 *ENERGIE* GmbH & Co. KG. All rights reserved.

Q3 *ENERGIE* GmbH & Co. KG
Moosmangstr. 8
87600 Kaufbeuren
German8341/9080 334